

WATER FEATURES

INSTRUCTIONS & INSTALLATION INFORMATION

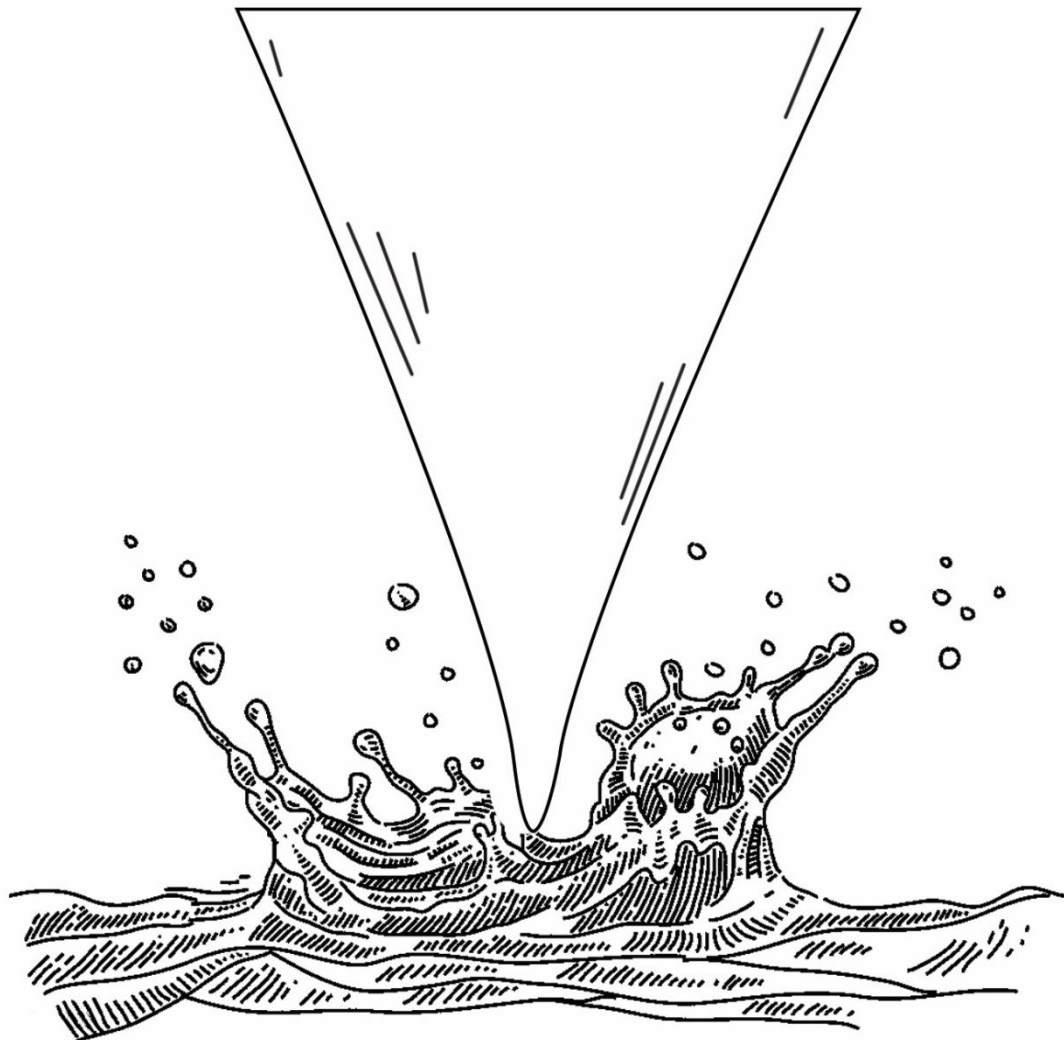

CONTENTS

Section 1: Receiving & Safety Warnings

Section 2: Setup & Installation

Section 3: Warranty

Section 4: Dimensions & Diagrams

Section 5: Troubleshooting

WARNING

Read this material before using this product. Failure to do so can result in serious injury. **SAVE THIS MANUAL.**

SECTION 1: RECEIVING & SAFETY WARNINGS

RECEIVING CHECKLIST

Upon receiving unit from transportation carrier

- 1) Inspect the crate/pallet for damage
- 2) Check that Purchase Order/BOL paperwork matches paperwork on crate/pallet
- 3) Open top of crate/pallet and inspect unit for damage

*If damaged, please notify carrier immediately and sign "damaged" or do not receive. Please also notify Prism Hardscapes office immediately via email at warranty@prismhardscapes.com.

WARNING

FOR OUTDOOR USE ONLY.

Improper installation, adjustment, alteration, service or maintenance can cause injury or property damage. Read all installation, operating and maintenance instructions thoroughly before installing or servicing the equipment. This product must be installed and serviced by a contractor who is licensed and qualified in pool equipment by the jurisdiction in which the product will be installed where such state or local requirements exist. The maintainer must be a professional with sufficient experience in pool equipment installation and maintenance so that all of the instructions in this manual can be followed exactly.

Before installing this product, read and follow all warning notices and instructions that accompany this product. Failure to follow warning notices and instructions may result in property damage, personal injury, or death. Improper installation and/or operation may void the warranty.

SAFETY

ATTENTION INSTALLER - This manual contains important information about the installation, operation and safe use of this product. This information should be given to the owner/operator of this equipment.

Never leave children near unit without supervision. Never leave unit unattended when in use.

feature when in use. Do not stand on any part of this appliance. Never allow children to sit on or near unit, this could cause personal injury.

SAFETY

Inspections of this unit should be done prior to installation and on an annual basis by a certified technician. Frequent cleaning may be required depending on level of usage. It is the installer's responsibility to review all safe operating and safety procedures with the end user. All manuals and product information sheet must be left with end user.

It is important to inspect your unit before every use. Make sure there are no obstructions or combustible materials on or near unit.

Consistently check hoses and fittings for cracks, abrasions and leaks (at least once a month).

Do not leave pets or children unattended around unit. Use a designated fire pit or barbecue cover when not in use.

NEVER ATTEMPT TO MOVE YOUR UNIT BY YOURSELF

- WRAP FURNITURE BLANKET AROUND THE ENTIRE BODY OF THE UNIT
- PLACE A PIECE OF ¾" PLYWOOD BETWEEN DOLLY AND THE UNIT FOR INCREASED STABILITY WHILE MOVING
- USE DOLLY TO NAVIGATE THE UNIT TO THE FINAL POSITION



DO NOT USE A WHEELBARROW OR OTHER UNBALANCED EQUIPMENT TO MOVE UNIT

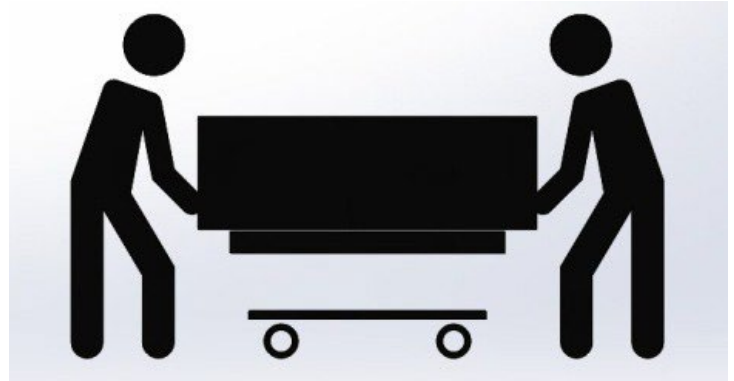

CAREFULLY REMOVE UNIT FROM CRATE AND PLACE ONTO MOVING DOLLY

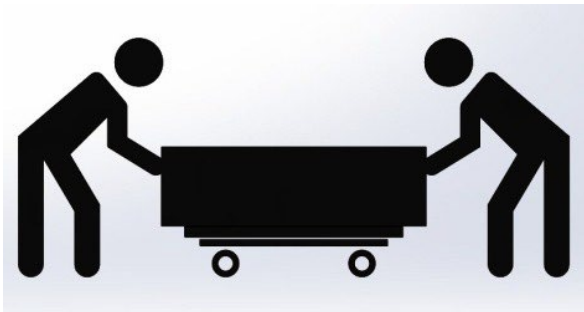

PLACE UNIT WITH BASE DOWN TO MOVE

OR

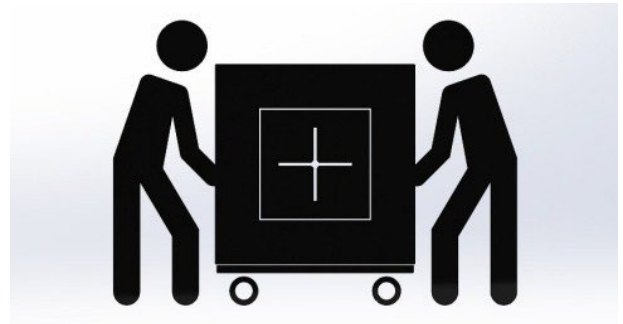

PLACE UNIT ON SIDE TO MOVE (ONLY FOR SQUARE OR RECTANGLE UNITS)

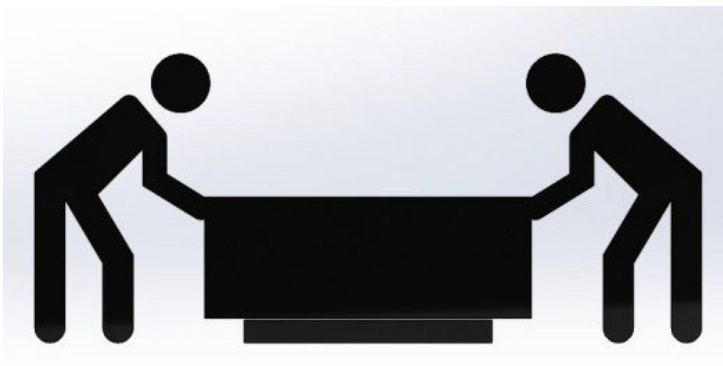

GENTLY PLACE UNIT INTO FINAL POSITION

⚠ WARNING

Before installing this product, read and follow all warning notices and instructions provided. Failure to do so may result in serious injury, property damage and/or death.

For additional product reference and copies of these instructions, visit our website at prismhardscapes.com

This product must be installed and serviced by a contractor or qualified installer who is licensed and/or certified within the jurisdiction where the product will reside. In the event no such state or local requirement exists, the installer or maintainer must be a qualified professional with sufficient experience in installation and maintenance of electric appliances. Prior to installation, read and follow all warning notices and instructions provided with this product.

Failure to do so may result in property damage, personal injury, and/or death. Improper installation and/or operation may result in serious injury, property damage, and/or death..

Improper installation and/or operation will void warranty.



CALIFORNIA PROPOSITION 65

This product can expose you to Chromium, which is known in the state of California to cause cancer, birth defects, or other reproductive harm.

For more information, go to: www.p65warnings.ca.gov

SECTION 2: SETUP & INSTALLATION

1. Install a 1" PVC water line in the middle of column. Piping must be reduced to ½ NPT or larger at each bowl, as shown in Figures 1 & 2. Note: The water connection must be located at the center of each bowl. The connections must be installed as shown in Figures 1 & 2.
2. Carefully place the water bowl in the final designated area. The water bowl must be anchored into its final position.
3. Level the Water Bowl using shims under the base of the bowl. Note: If not leveled properly, the spillway will not create an even water sheer effect. Permanently secure the base of the bowl and the stainless washer to the cap using 3M Scotch-Weld Epoxy Adhesive 2216 B/A. Silicone the gap between the stainless washer and the PVC water pipe. The water bowl should be watertight.
4. Cut the PVC water line to the desired height, and add a "T" fitting to the water pipe.
5. Turn on water supply and adjust the water inlet flow so that it will drain at the same rate.

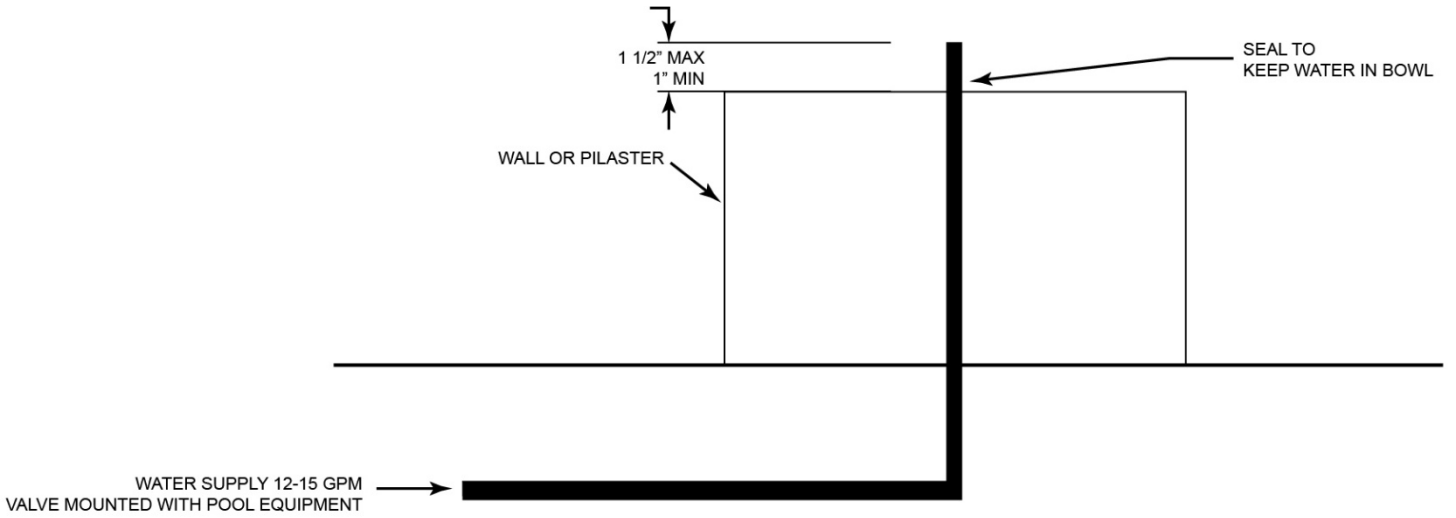

FIGURE 1: PIPING SETUP FOR BOWL

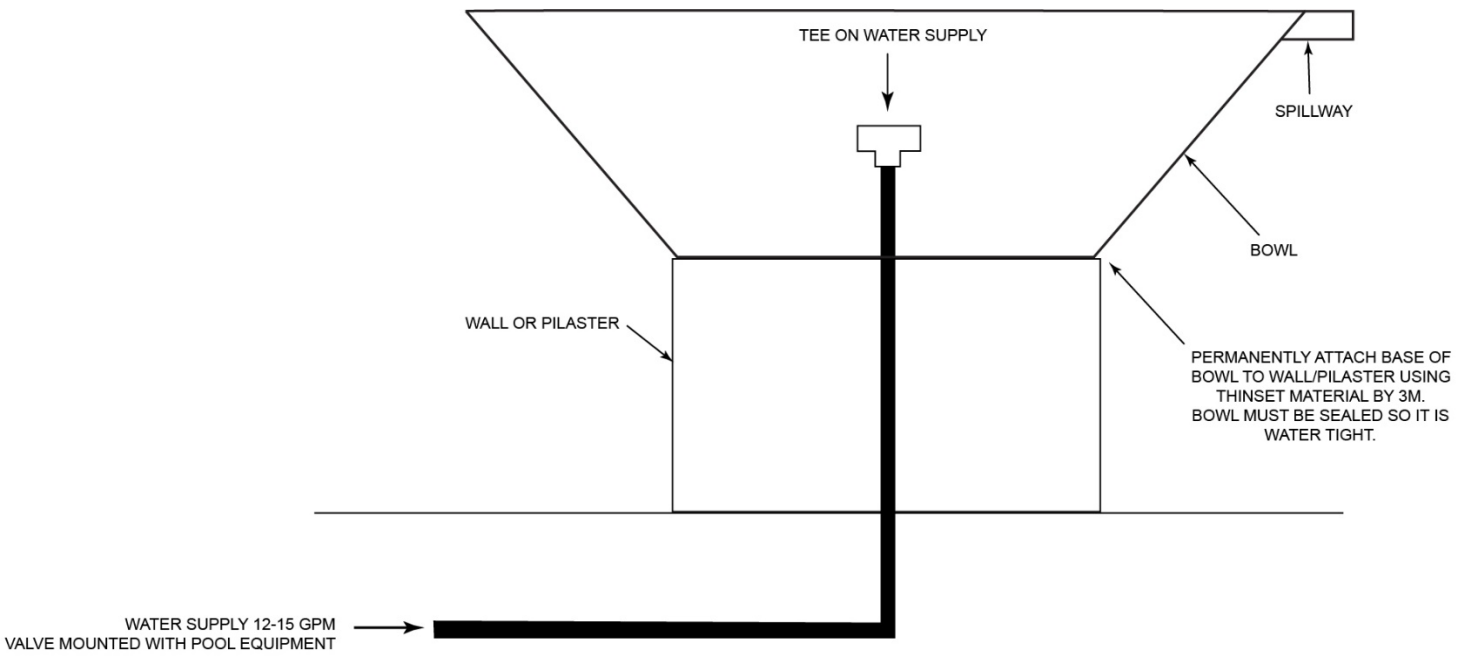

FIGURE 2: FINAL BOWL SETUP

SECTION 3: WARRANTY

Prism Hardscapes LLC offers a 2-year limited warranty against manufactured defects. Prism Hardscapes will replace product which has proven to be defective in workmanship and material. The buyer must provide proof of purchase date by the end user of product. Prism Hardscapes must have the opportunity to verify the alleged defect this may include a site visit to inspect product. If unit is confirmed defective and cannot be repaired Prism Hardscapes will replace unit FOB PRISM HARDSCAPES facility. Buyer will be responsible for arranging shipping associated with replacement. All labor associated with installation will be responsibility of end user.

Prism Hardscapes will not be responsible for any defects which result for misuse, alteration or abuse. Prism Hardscapes is not responsible for any damage or injury that arise from misuse of product.

SECTION 4: DIMENSIONS & DIAGRAMS

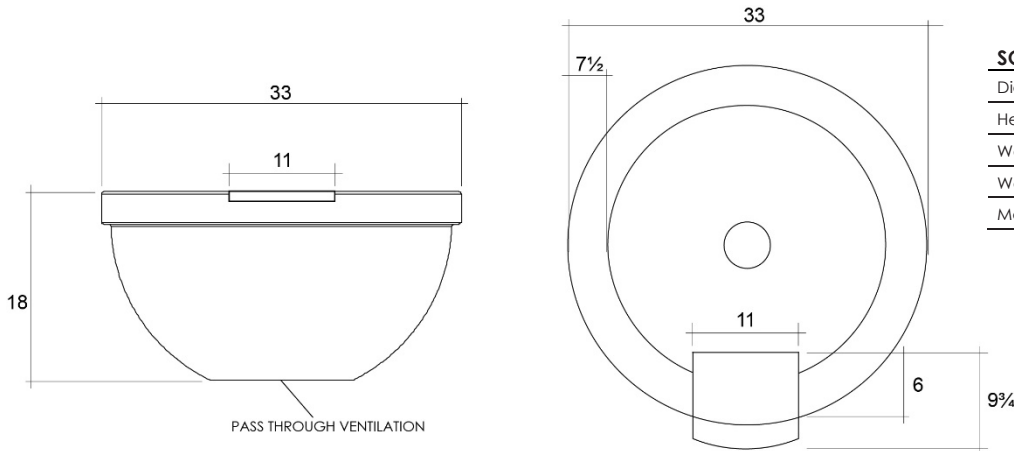

SORRENTO SPECIFICATIONS

Diameter	33"
Height	18"
Water Flow	15 GPM
Weight	196 lbs.
Material	Glass fiber reinforced concrete

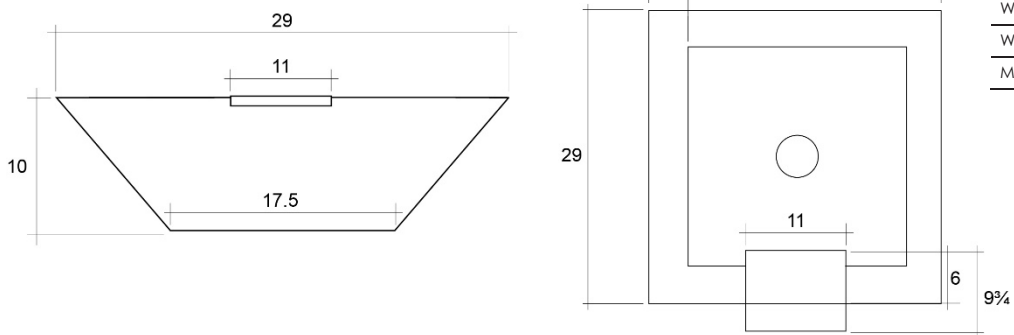

LOMBARD-P SPECIFICATIONS

Length/Width	29"
Height	14"
Water Flow	15 GPM
Weight	90 lbs.
Material	Glass fiber reinforced concrete

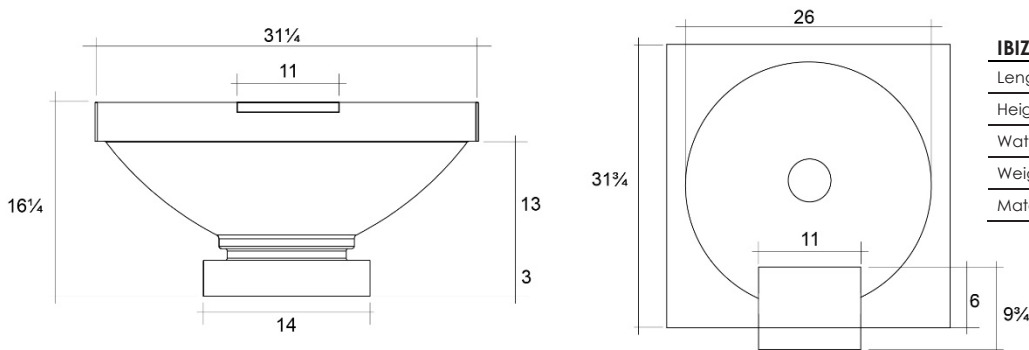

IBIZA SPECIFICATIONS

Length/Width	31 1/4"
Height	16 1/4"
Water Flow	15 GPM
Weight	176 lbs.
Material	Glass fiber reinforced concrete

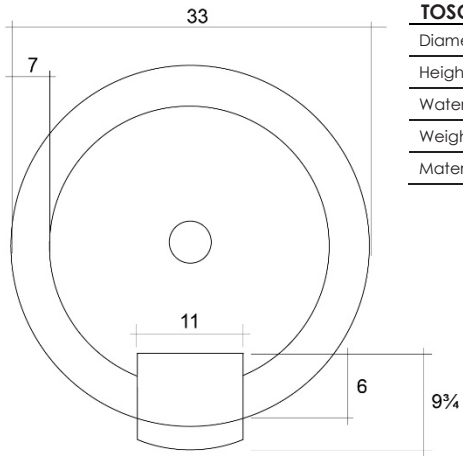
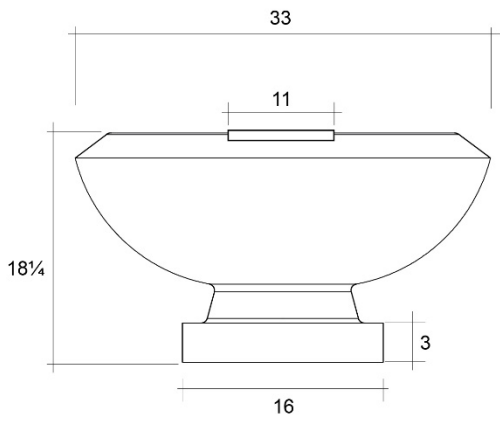

TOSCANO SPECIFICATIONS

Diameter	33"
Height	18 1/4"
Water Flow	15 GPM
Weight	180 lbs.
Material	Glass fiber reinforced concrete

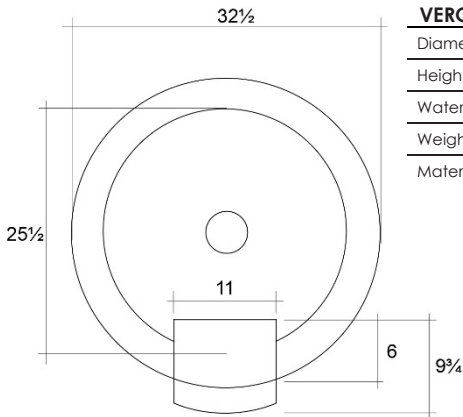
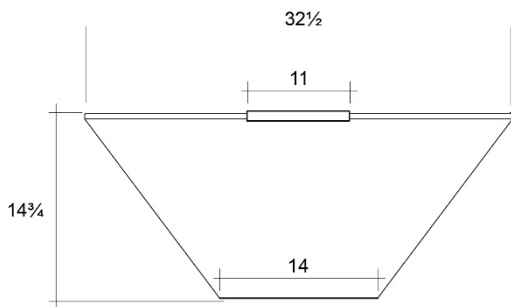

VERONA SPECIFICATIONS

Diameter	32 1/2"
Height	14 3/4"
Water Flow	15 GPM
Weight	140 lbs.
Material	Glass fiber reinforced concrete

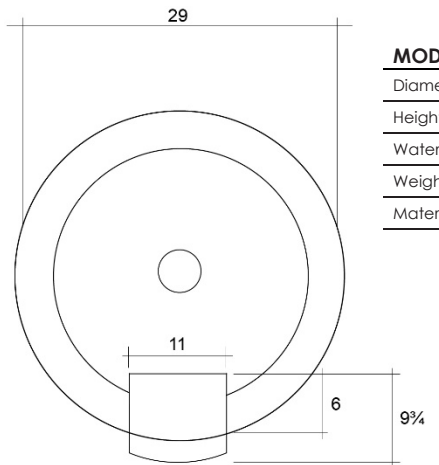
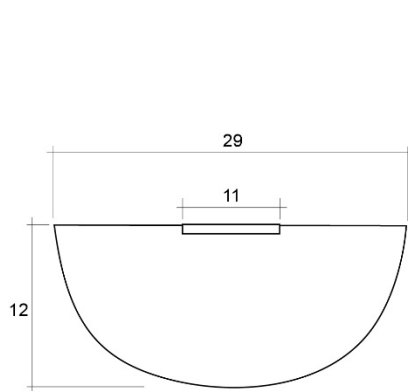

MODERNO 2-P SPECIFICATIONS

Diameter	29"
Height	12"
Water Flow	15 GPM
Weight	110 lbs.
Material	Glass fiber reinforced concrete

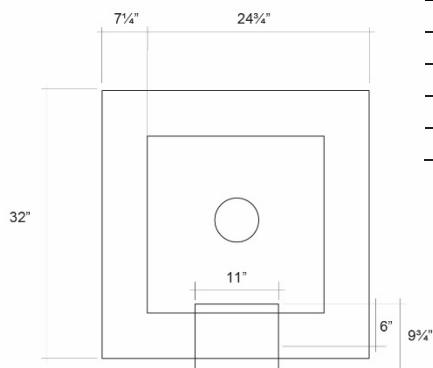
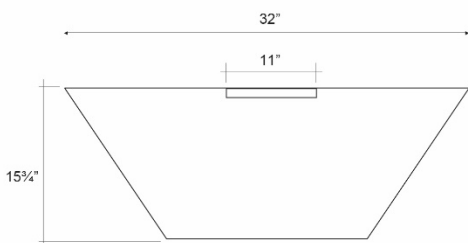

LOMBARD-P TALL SPECIFICATIONS

Diameter	32"
Height	15 1/4"
Water Flow	15 GPM
Weight	280 lbs.
Material	Glass fiber reinforced concrete

SECTION 5: TROUBLESHOOTING

WATER IS LEAKING FROM UNIT

Possible Cause	How to Fix
Unit is not properly sealed	Empty the water from the unit and double check the bottom seal for any cracks or leaks.

WATER SPILLING OVER THE SIDES OF THE UNIT

Possible Cause	How to Fix
Water Flow is too high	Reduce the flow of water to the unit as the spillway cannot empty the water fast enough.

COLOR FADING

Possible Cause	How to Fix
Exposure	Concrete Units: Purchase cement sealer at your local brick and mortar retailer and apply a coat to concrete areas every year.