



PRISM HARDSCAPES
Outdoor Living Products

2021 Product Guide



Tavola 5

We believe in spaces that are not only designed for living, but for making memories and enjoying life.

Prism Hardscapes is a progressive company that focuses on well designed outdoor living products. We are committed to current architectural trends, visionary designs, coupled with handcrafted techniques that allow for products that are beautiful as well as affordable. We are always at the forefront of exceptional product design, quality, and value in the outdoor living space.

Backed by over 100 years of experience, Natco Home is a family owned business that was established in 1917. Natco Home is one of the largest and most respected companies in the Home Textiles, and Outdoor Living Products industries with wholly owned manufacturing facilities in Georgia, Maine, California and Toronto, as well as several joint ventures in China, Poland, Egypt, Turkey and Mexico. Natco Home delivers today's hottest home fashion colors and designs at surprisingly affordable price points.

2021 PRODUCT CATALOG

05	Moderno 1	21	Pentola 1	43	Cilindro
05	Moderno 2	21	Pentola 2	44	Triton
06	Moderno 3	22	Pentola 3	46	Ovale
06	Moderno 4	22	Scatola	49	Fairmont
08	Moderno 5	24	Pebble	50	Hampton
08	Moderno 6	24	Rotondo	51	Manchester
09	Moderno 8	25	Lombard	52	Falo (Wood Burning Unit)
12	Tavola 1	25	Embarcadero	54	Fire Media
12	Tavola 2	28	Propane Enclosures	56	PH-Ignite
13	Tavola 3	29	Lombard (Pedestal)	57	Ignition Options
13	Tavola 4	29	Embarcadero (Pedestal)	59	Burner Assembly
14	Tavola 5	30	Moderno 70	61	Divano
14	Tavola 6	32	Embarcadero 60		
16	Tavola 7	33	Largo 72		
16	Tavola 8	34	Rotondo 80		
17	Tavola 42	36	Fuego Series		
17	Tavola 66 Slim	38	EDEL Copper Units		
18	Tavola 110	40	Tuscany Collection		
20	Porto 58	41	Tavola 72 Narrow Series		
20	Porto 68	42	Piazza		

A photograph of an outdoor patio at night. The patio is paved with large, light-colored stone tiles. In the center, there is a square fire pit with a blue flame. Surrounding the fire pit are several pieces of outdoor furniture: a black metal sofa with brown cushions, a black metal armchair with brown cushions, and two large, olive-green ottomans. To the left, there is a stone fireplace with a built-in grill. The background features a wooden fence, trees, and a house with a balcony. String lights are visible in the upper part of the image, and the overall atmosphere is warm and inviting.

We believe in spaces that are designed for living,
making memories, and enjoying life.

Porto 68

Moderno Collection



Moderno 6

Moderno 1



SPECIFICATIONS

Diameter	39"
Height	18"
Surface	1½"
Burner Size	15"/65,000 BTUs
Weight	210 lbs.
Fuel Source	LP or NG
Ignition	Key valve
Material	Glass fiber reinforced concrete
Media	Lava rock

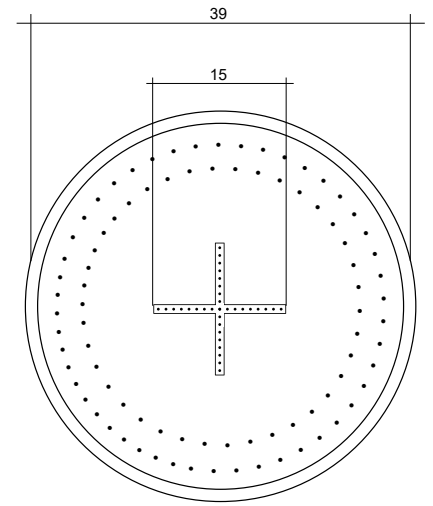
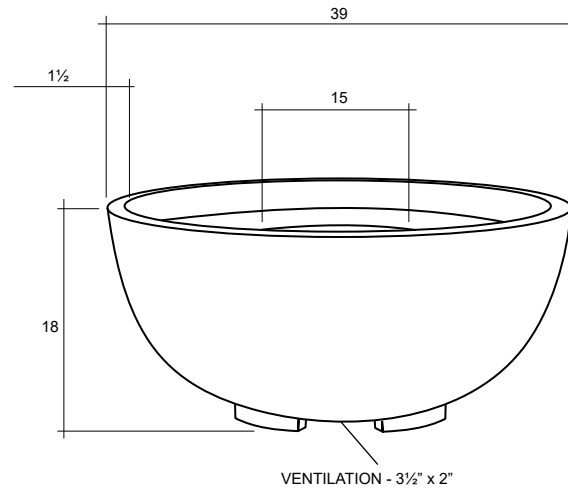

Moderno 2



SPECIFICATIONS

Diameter	29"
Height	12"
Surface	2¾"
Burner Size	15"/65,000 BTUs
Weight	90 lbs.
Fuel Source	LP or NG
Ignition	Key valve
Material	Glass fiber reinforced concrete
Media	Lava rock

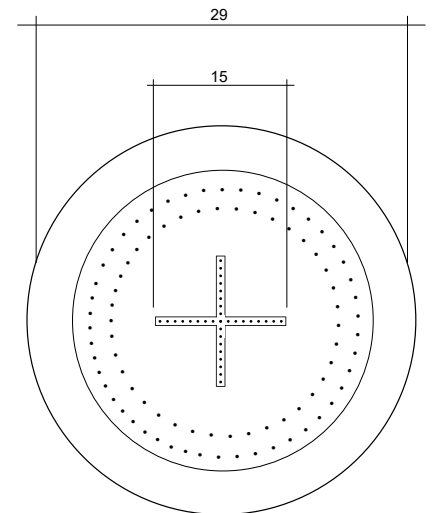
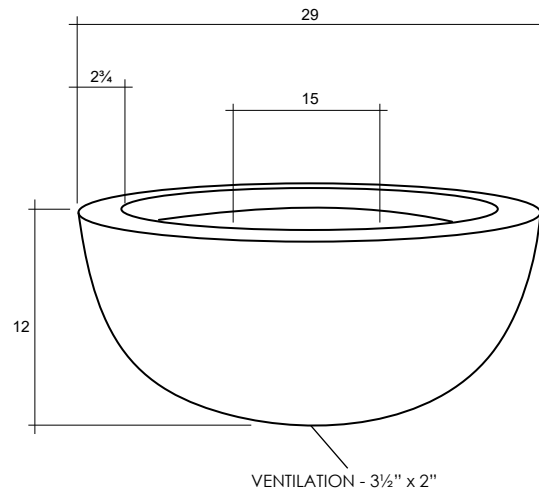

Moderno 3



SPECIFICATIONS

Diameter	30"
Height	18"
Surface	3"
Burner Size	15"/65,000 BTUs
Weight	125 lbs.
Fuel Source	LP or NG
Ignition	Key valve
Material	Glass fiber reinforced concrete
Media	Lava rock

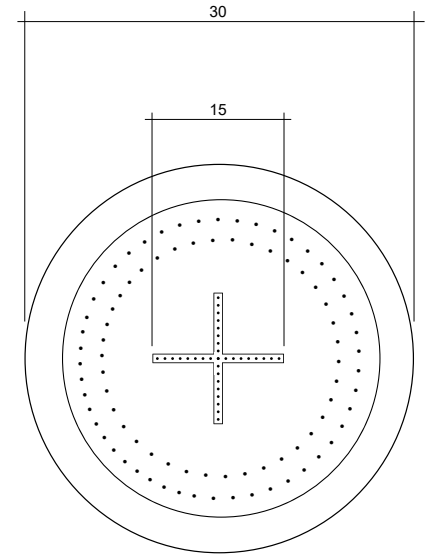
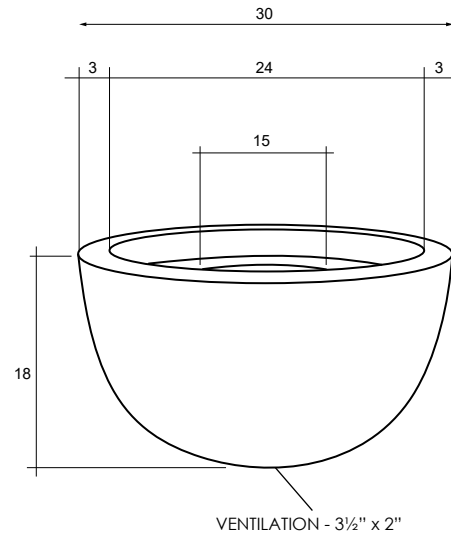

Moderno 4



SPECIFICATIONS

Diameter	48"
Height	17"
Surface	6" (also available in 4")
Burner Size	18"/65,000 BTUs
Weight	400 lbs.
Fuel Source	LP or NG
Ignition	Key valve
Material	Glass fiber reinforced concrete
Media	Lava rock

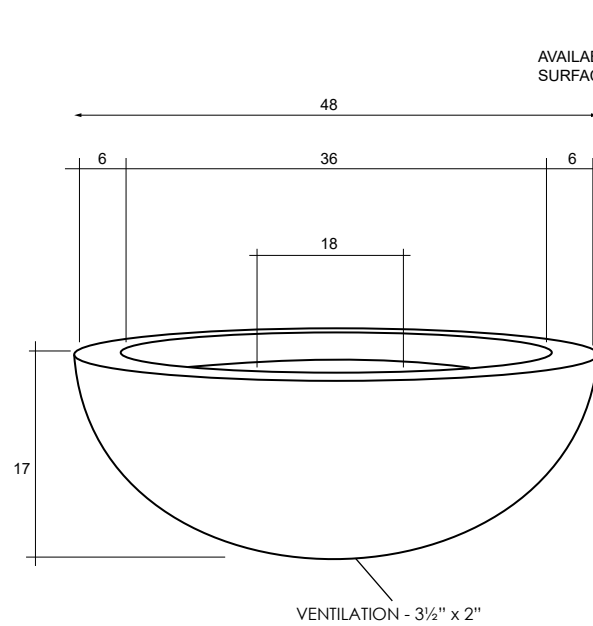

AVAILABLE WITH 4" SURFACE AREA

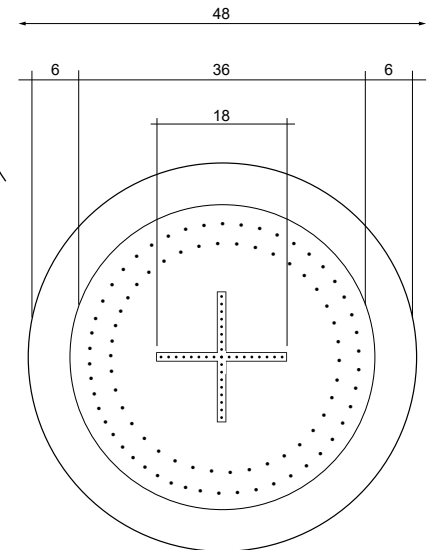

DIAMETER | 48"



Moderno 4

Moderno 5



SPECIFICATIONS

Diameter	36"
Height	16"
Surface	5½"
Burner Size	15"/65,000 BTUs
Weight	250 lbs.
Fuel Source	LP or NG
Ignition	Key valve
Material	Glass fiber reinforced concrete
Media	Lava rock

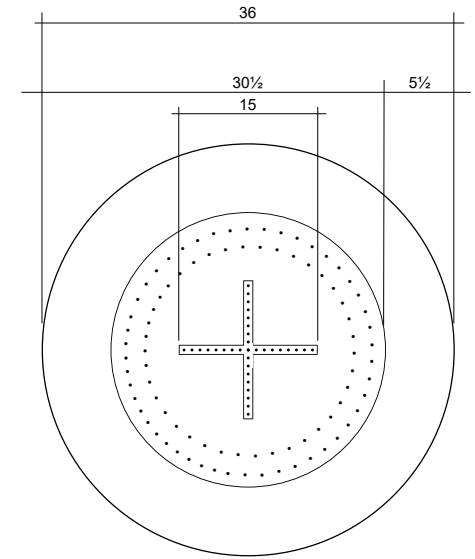
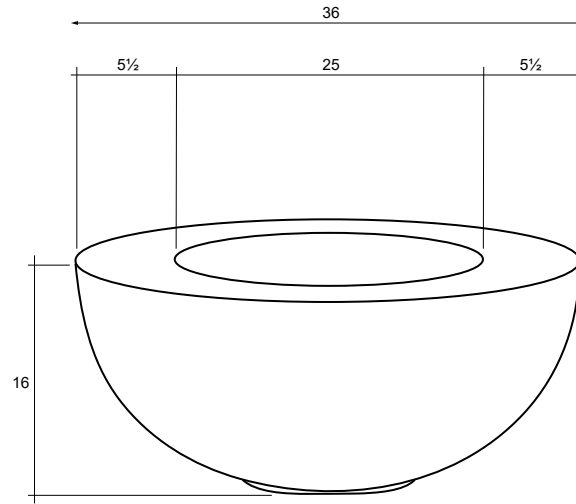

Moderno 6



SPECIFICATIONS

Diameter	39"
Height	15"
Surface	5½"
Burner Size	15"/65,000 BTUs
Weight	275 lbs.
Fuel Source	LP or NG
Ignition	Key valve
Material	Glass fiber reinforced concrete
Media	Lava rock

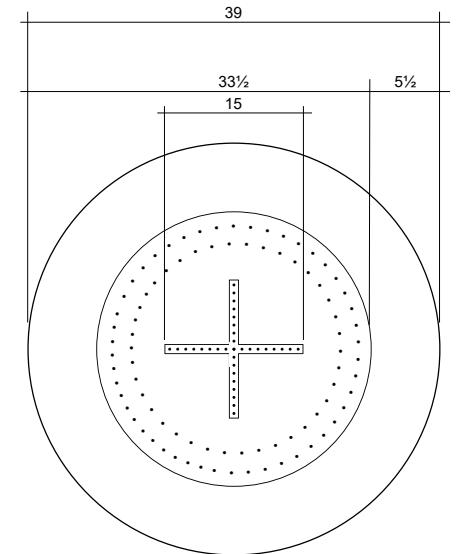
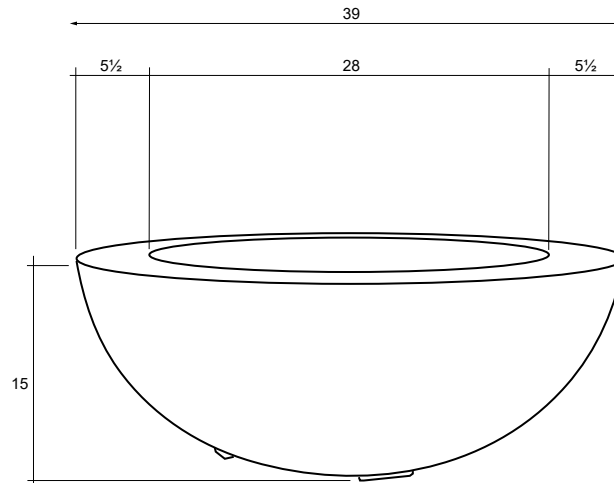



SPECIFICATIONS

Diameter	39"
Height	18"
Surface	5"
Burner Size	15"/65,000 BTUs
Weight	225 lbs.
Fuel Source	LP or NG
Ignition	Key valve
Material	Glass fiber reinforced concrete
Media	Lava rock

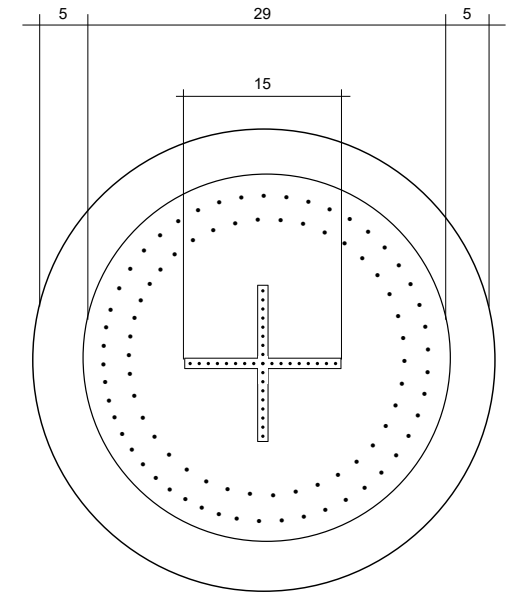
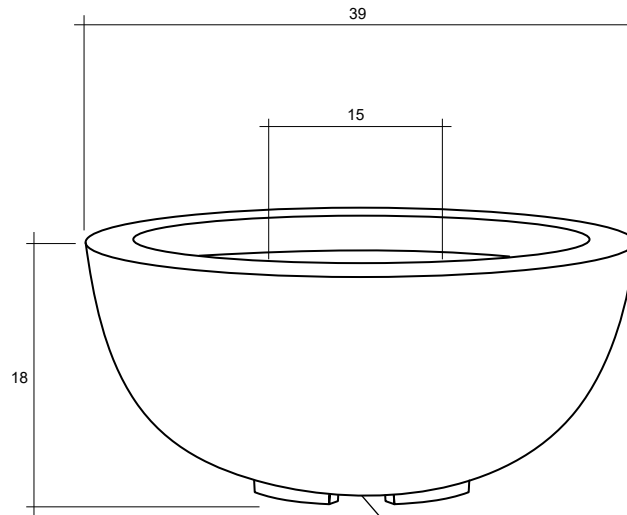

Moderno 8

Tavola Collection





Tavola 6

Tavola 1

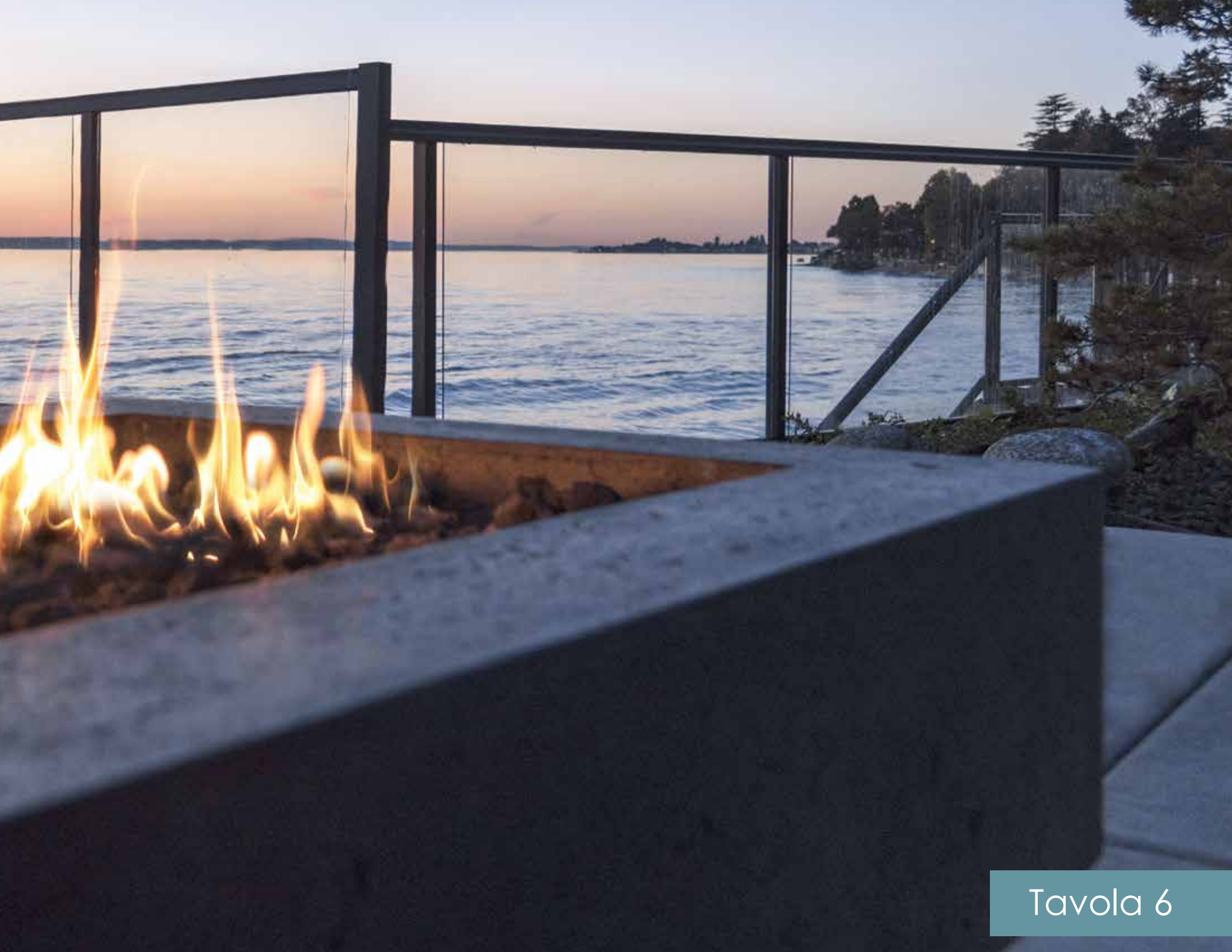

SPECIFICATIONS

Width	38"
Length	56"
Height	16"
Surface	11"
Burner Size	24"/65,000 BTUs
Weight	360 lbs.
Fuel Source	LP or NG
Ignition	Key valve
Material	Glass fiber reinforced concrete
Media	Lava rock



Tavola 2



SPECIFICATIONS

Width	36"
Length	36"
Height	16"
Surface	8 1/4"
Burner Size	15"/65,000 BTUs
Weight	240 lbs.
Fuel Source	LP or NG
Ignition	Key valve
Material	Glass fiber reinforced concrete
Media	Lava rock

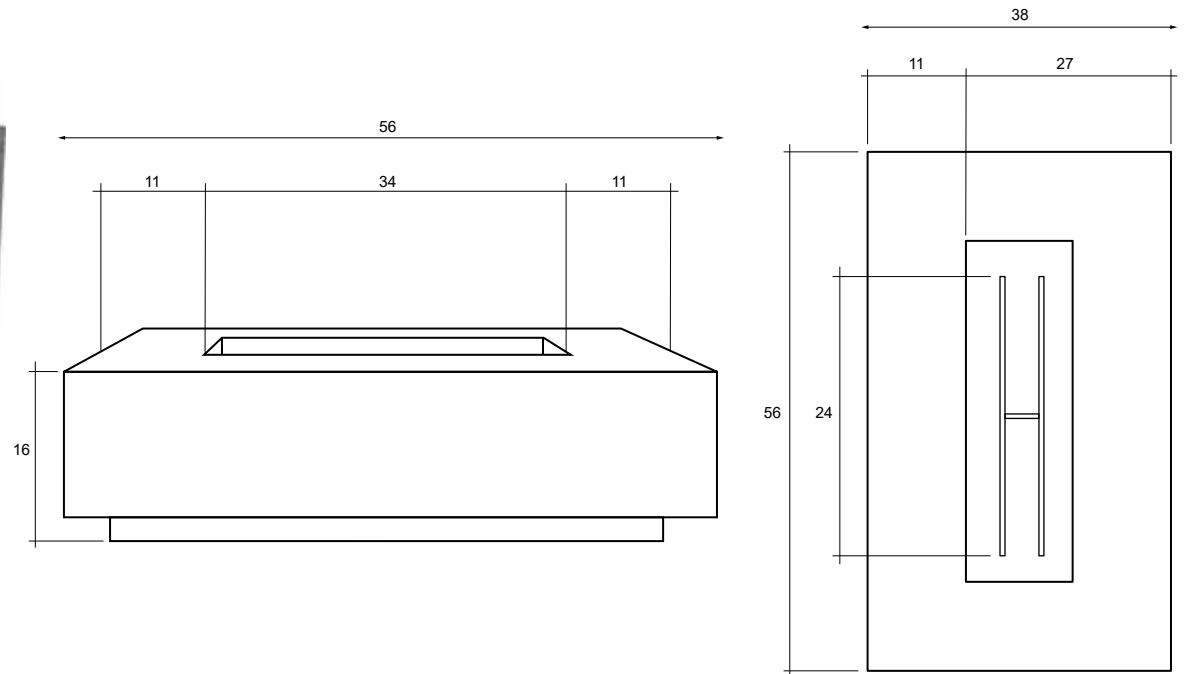

Tavola 3



SPECIFICATIONS

Width	48"
Length	48"
Height	16"
Surface	11"
Burner Size	18"/65,000 BTUs
Weight	450 lbs.
Fuel Source	LP or NG
Ignition	Key valve
Material	Glass fiber reinforced concrete
Media	Lava rock

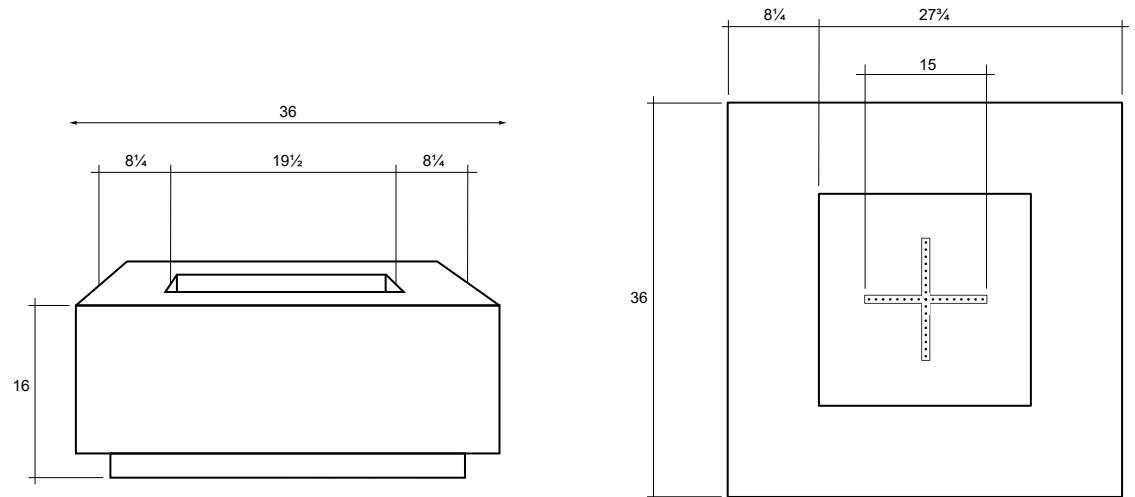

Tavola 4



SPECIFICATIONS

Width	38"
Length	66"
Height	16"
Surface	16"/11"
Burner Size	24"/65,000 BTUs
Weight	500 lbs.
Fuel Source	LP or NG
Ignition	Key valve
Material	Glass fiber reinforced concrete
Media	Lava rock

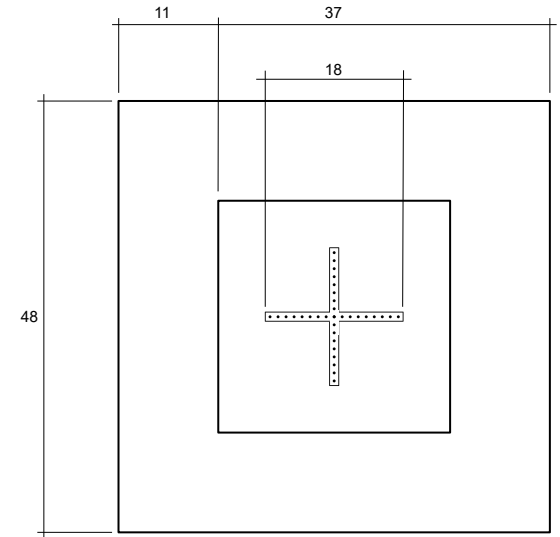
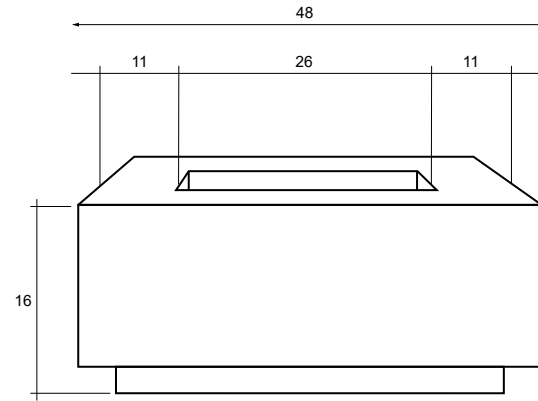

Tavola 5



SPECIFICATIONS

Width	38"
Length	80"
Height	16"
Surface	11"/33¼"
Burner Size	24"/65,000 BTUs
Weight	650 lbs.
Fuel Source	LP or NG
Ignition	Key valve
Material	Glass fiber reinforced concrete
Media	Lava rock

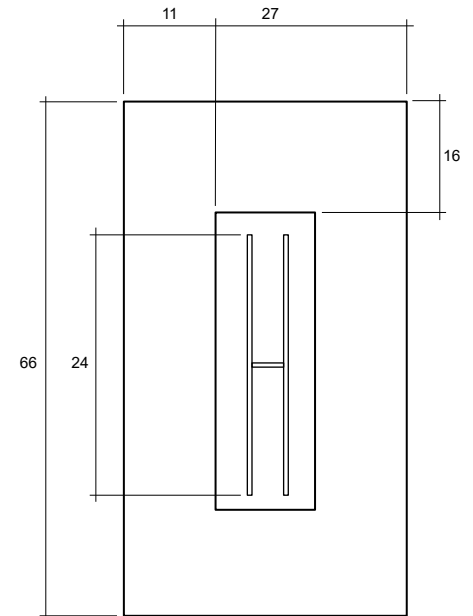
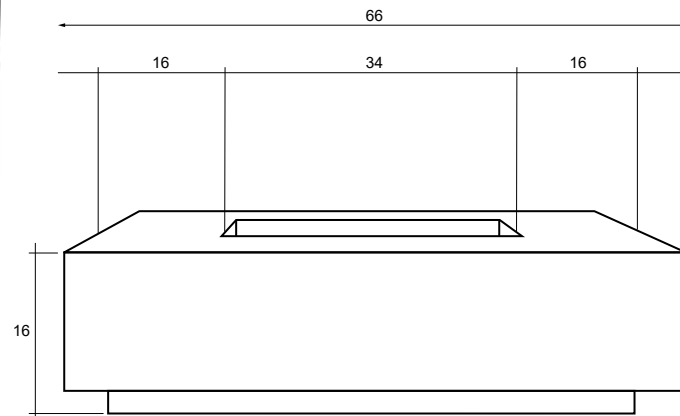

Tavola 6



SPECIFICATIONS

Width	38"
Length	90"
Height	16"
Surface	11"
Burner Size	60"/90,000 BTUs
Weight	650 lbs.
Fuel Source	LP or NG
Ignition	Key valve
Material	Glass fiber reinforced concrete
Media	Lava rock

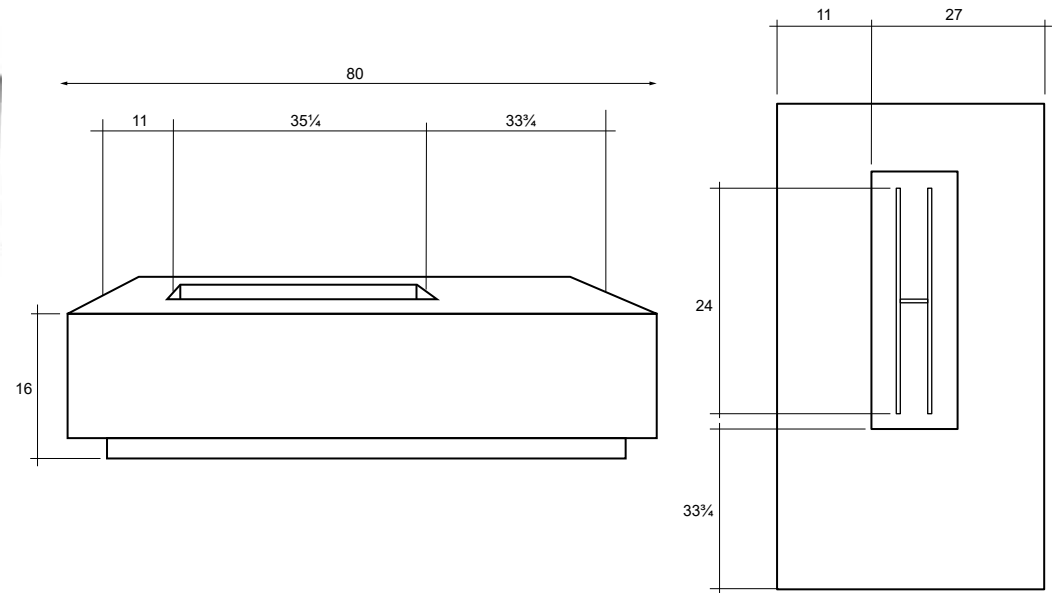



Tavola 4

Tavola 7

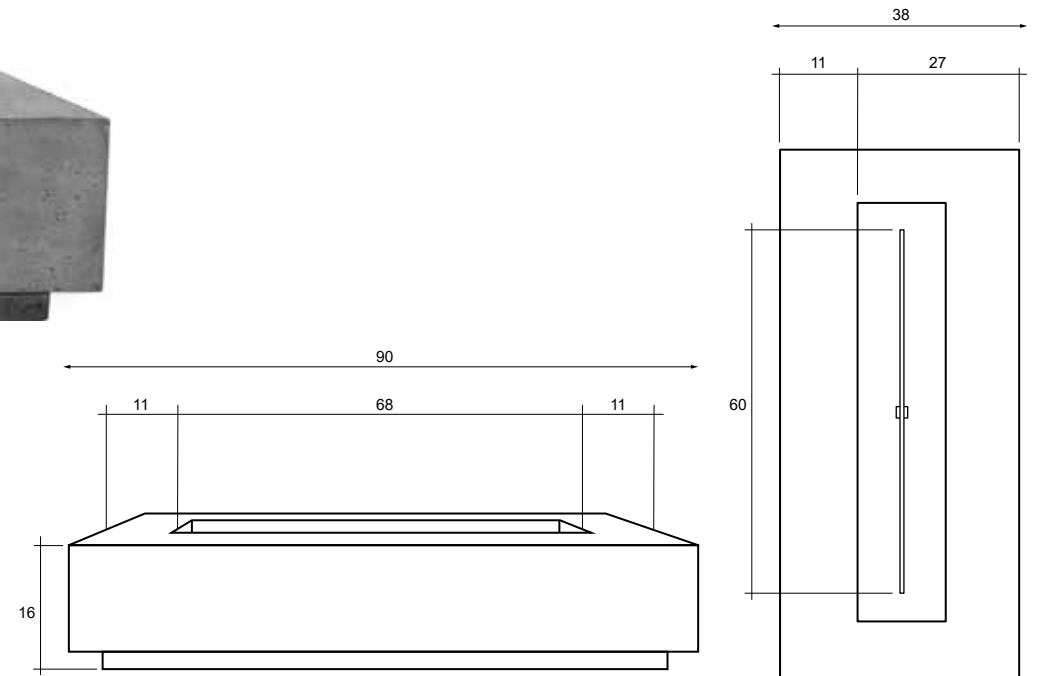

SPECIFICATIONS

Width	50"
Length	60"
Height	16"
Surface	16"
Burner Size	24"/65,000 BTUs
Weight	500 lbs.
Fuel Source	LP or NG
Ignition	Key valve
Material	Glass fiber reinforced concrete
Media	Lava rock



Tavola 8



SPECIFICATIONS

Width	32"
Length	60"
Height	16"
Surface	13"/8"
Burner Size	24"/65,000 BTUs
Weight	320 lbs.
Fuel Source	LP or NG
Ignition	Key valve
Material	Glass fiber reinforced concrete
Media	Lava rock

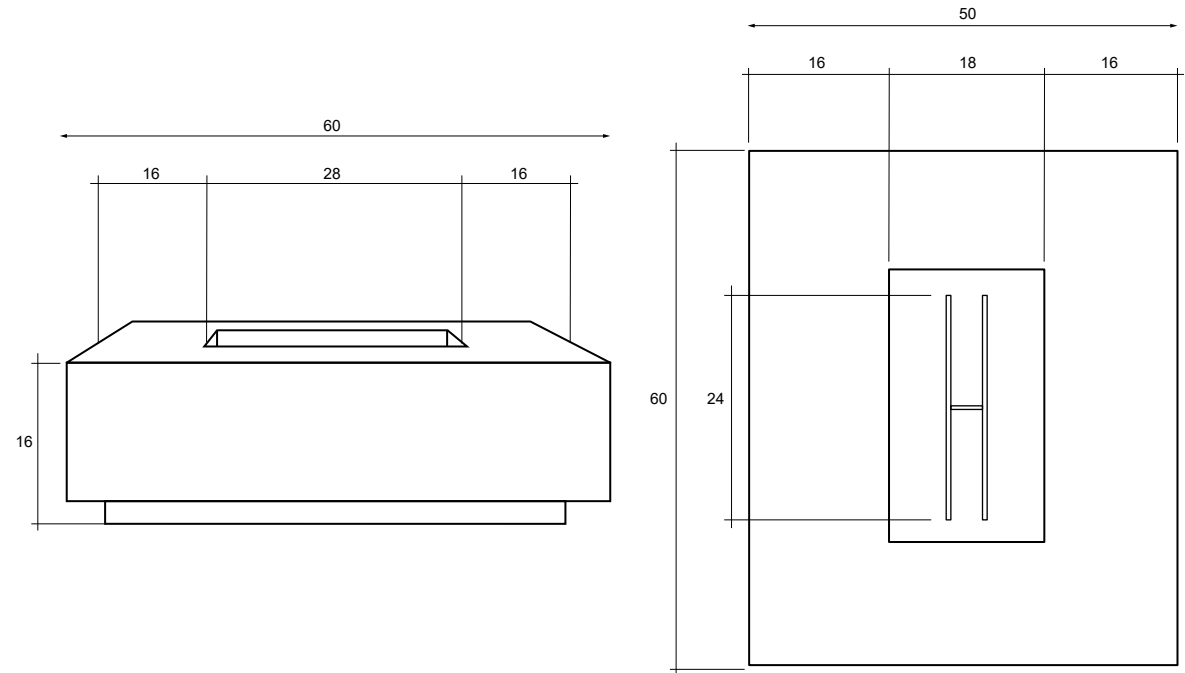

Tavola 42



SPECIFICATIONS

Width	42"
Length	42"
Height	16"
Surface	11 1/4"
Burner Size	15"/65,000 BTUs
Weight	360 lbs.
Fuel Source	LP or NG
Ignition	Key valve
Material	Glass fiber reinforced concrete
Media	Lava rock

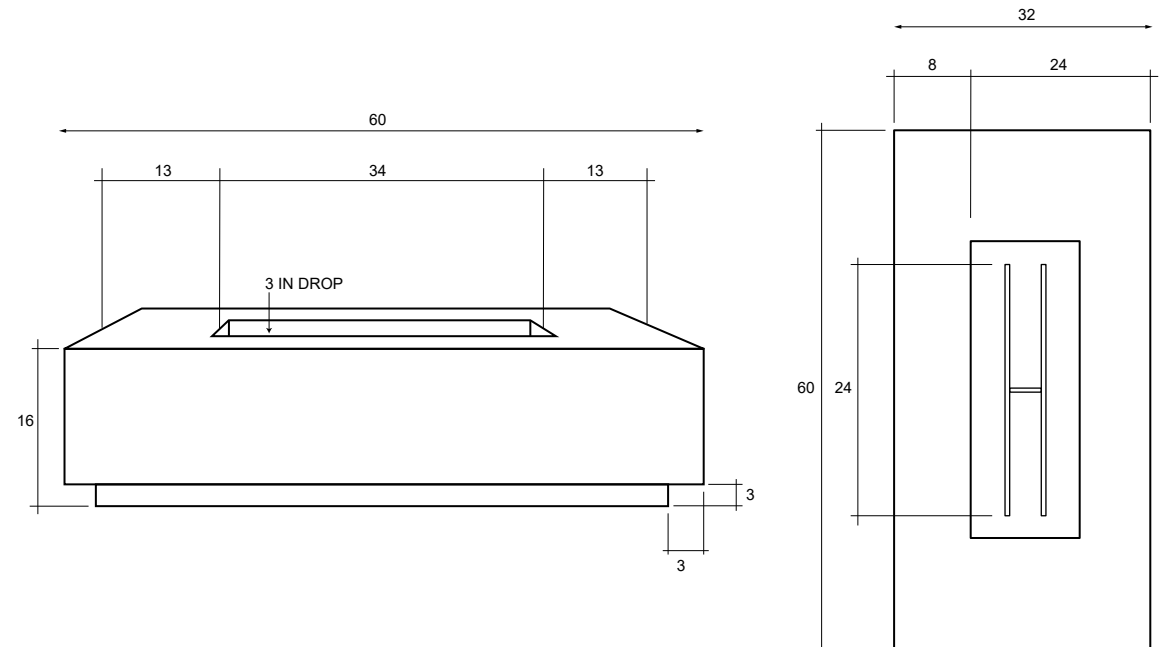

Tavola 66 Slim



SPECIFICATIONS

Width	30"
Length	66"
Height	16"
Surface	16"/9"
Burner Size	24"/65,000 BTUs
Weight	320 lbs.
Fuel Source	LP or NG
Ignition	Key valve
Material	Glass fiber reinforced concrete
Media	Lava rock

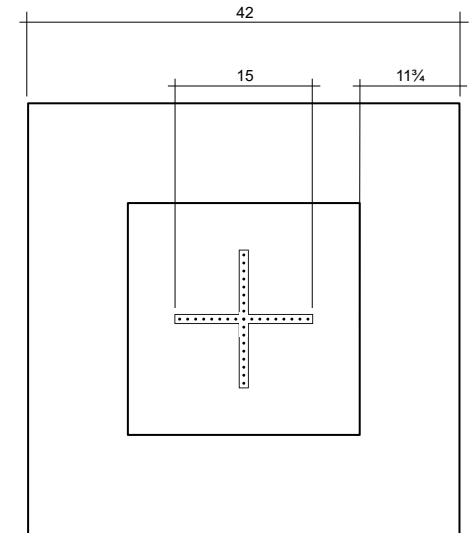
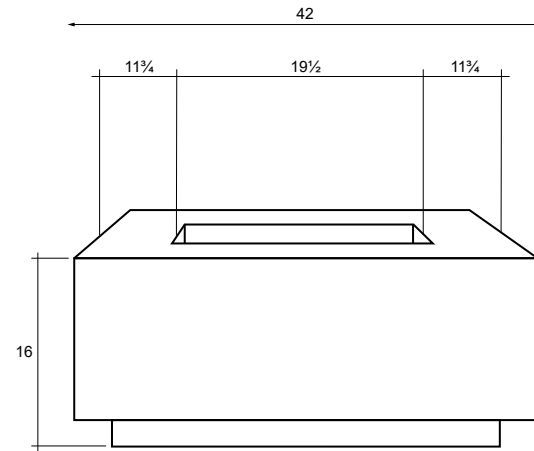

Tavola 110



SPECIFICATIONS

Width	38"
Length	110"
Height	16"
Surface	11"
Burner Size	80"/90,000 BTUs
Weight	750 lbs.
Fuel Source	LP or NG
Ignition	Key valve
Material	Glass fiber reinforced concrete
Media	Lava rock

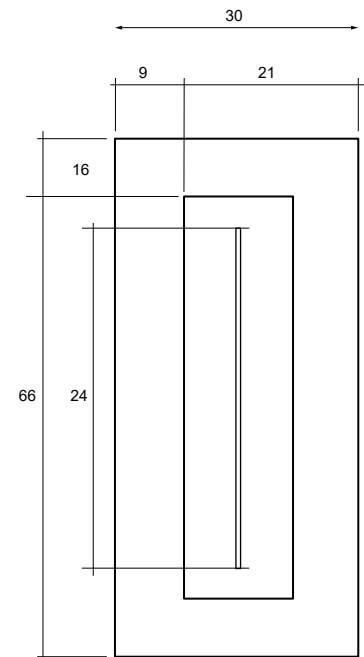
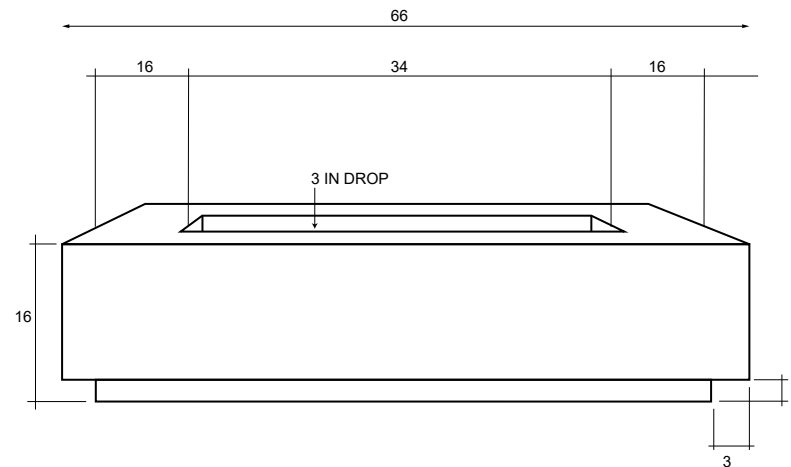
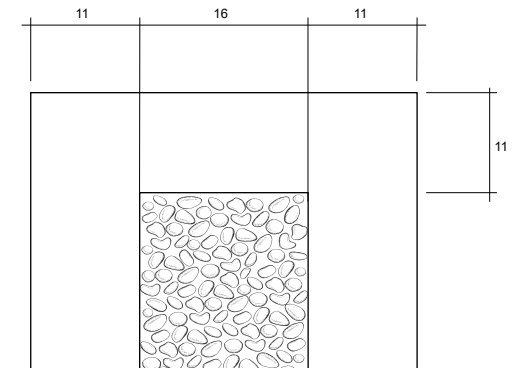
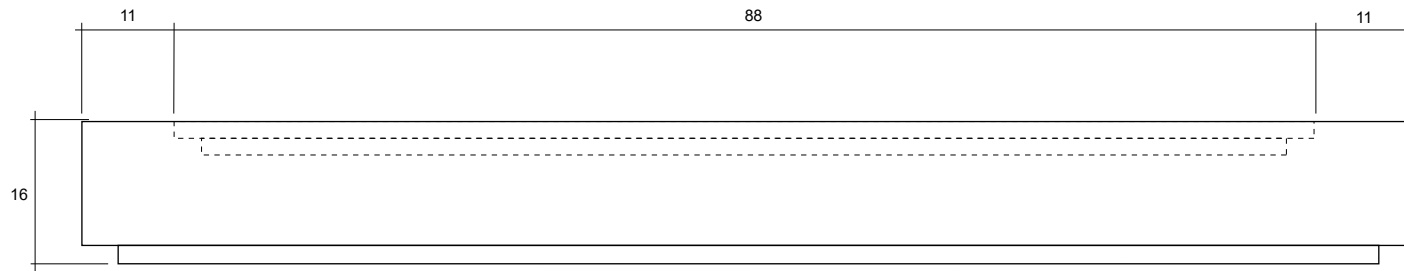



Porto 68

Porto 58 (Enclosed Propane Unit)



SPECIFICATIONS

Width	38"
Length	58"
Height	22"
Surface	12"/11"
Burner Size	24"/65,000 BTUs
Weight	450 lbs.
Fuel Source	Enclosed propane unit
Ignition	Key valve
Material	Glass fiber reinforced concrete
Media	Lava rock

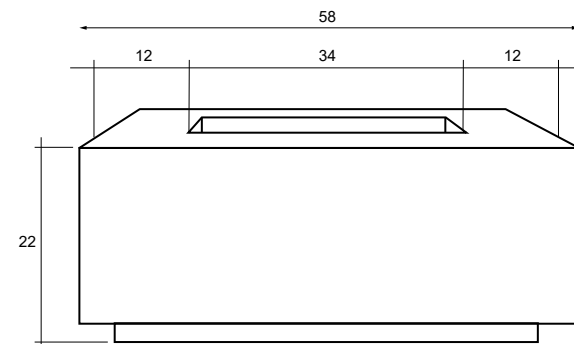

Porto 68 (Enclosed Propane Unit)



SPECIFICATIONS

Width	38"
Length	68"
Height	22"
Surface	17"/11"
Burner Size	24"/65,000 BTUs
Weight	550 lbs.
Fuel Source	Enclosed propane unit
Ignition	Key valve
Material	Glass fiber reinforced concrete
Media	Lava rock

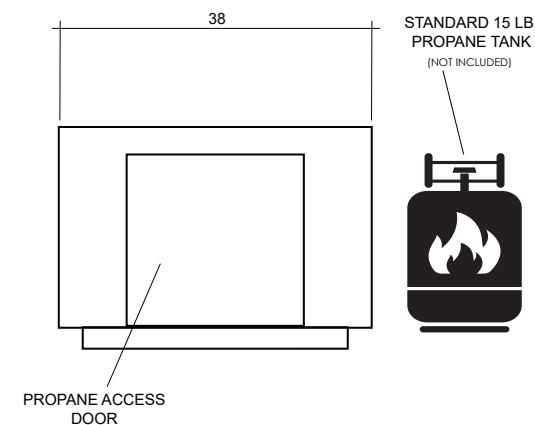
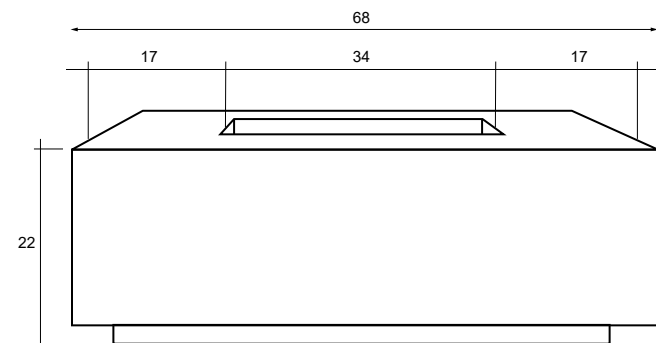

Pentola 1



SPECIFICATIONS

Diameter	24"
Height	28"
Burner Size	15"/65,000 BTUs
Weight	150 lbs.
Fuel Source	LP or NG
Ignition	Key valve
Material	Glass fiber reinforced concrete
Media	Lava rock

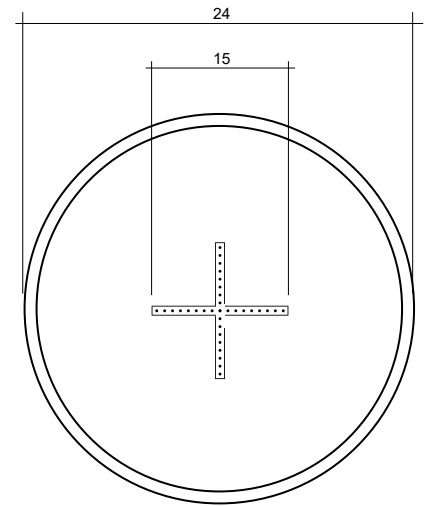
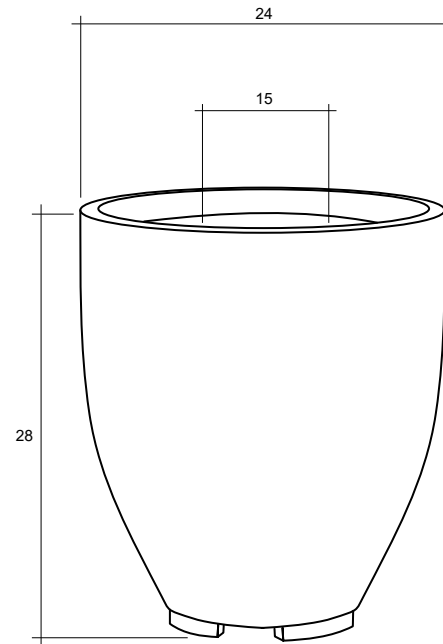

Pentola 2



SPECIFICATIONS

Diameter	24"
Height	21"
Burner Size	15"/65,000 BTUs
Weight	125 lbs.
Fuel Source	LP or NG
Ignition	Key valve
Material	Glass fiber reinforced concrete
Media	Lava rock

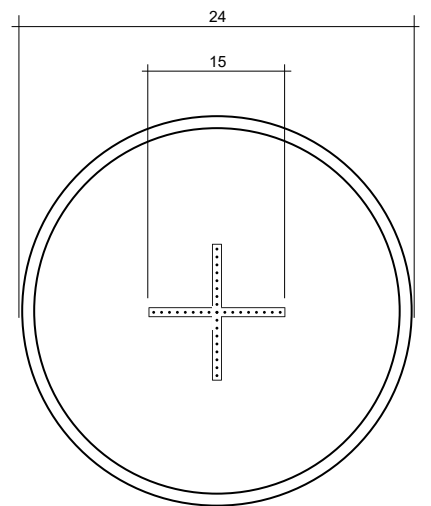
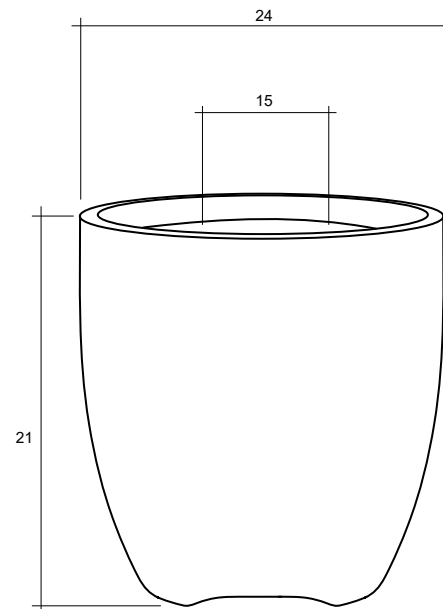

Pentola 3 (Enclosed Propane Unit)



SPECIFICATIONS

Diameter	24"
Height	26"
Burner Size	15"/65,000 BTUs
Weight	135 lbs.
Fuel Source	Enclosed propane
Ignition	Key valve
Material	Glass fiber reinforced concrete
Media	Lava rock

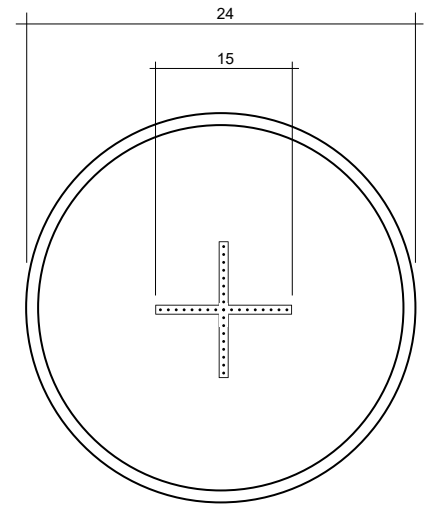
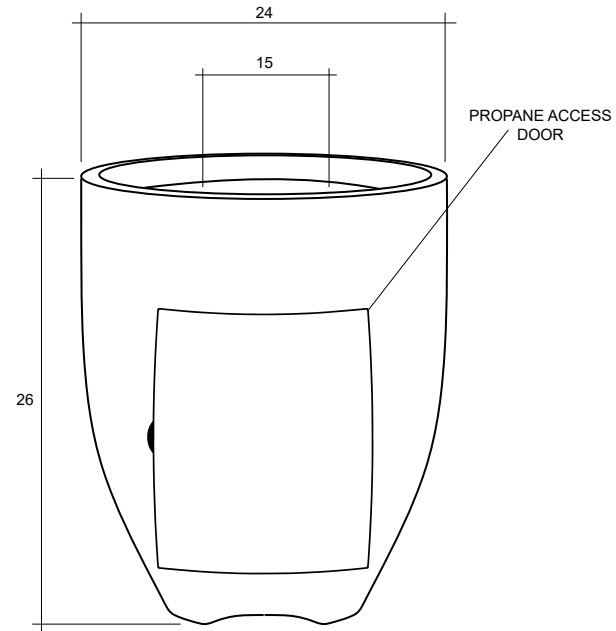

Scatola



SPECIFICATIONS

Width	20"
Height	18"
Surface	3"
Burner Size	6"/65,000 BTUs
Weight	130 lbs.
Fuel Source	LP or NG
Ignition	Key valve
Material	Glass fiber reinforced concrete
Media	Lava rock

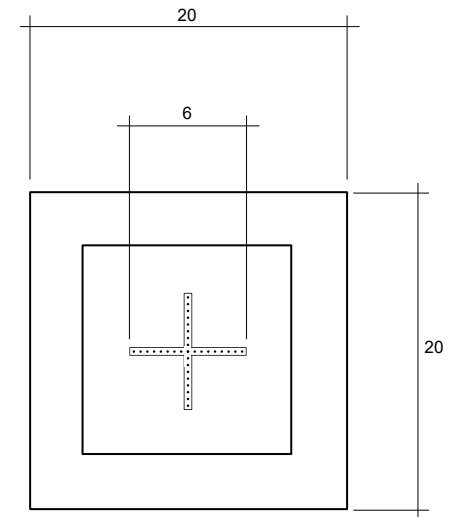
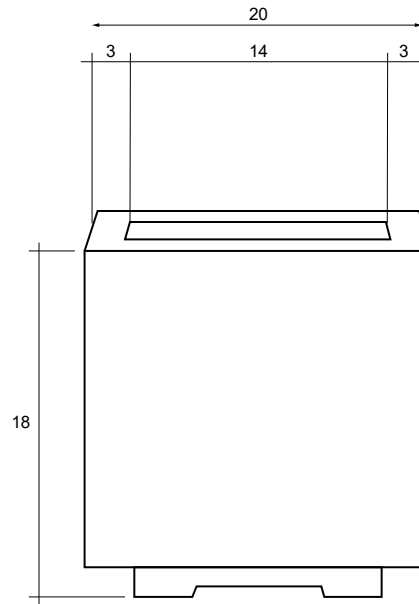



Rotondo

Pebble



SPECIFICATIONS

Width	38"
Length	56"
Height	16"
Burner Size	24" / 65,000 BTUs
Weight	350 lbs.
Fuel Source	LP or NG
Ignition	Key valve
Material	Glass fiber reinforced concrete
Media	Lava rock

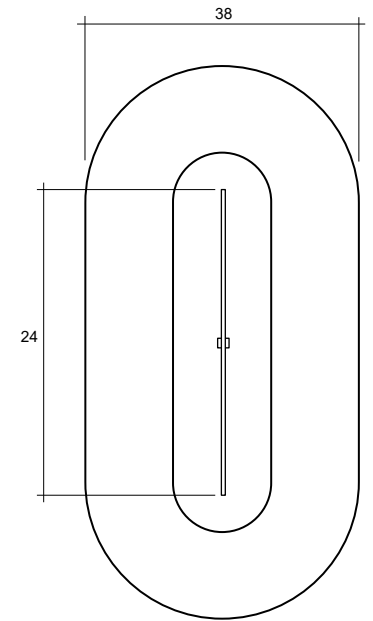
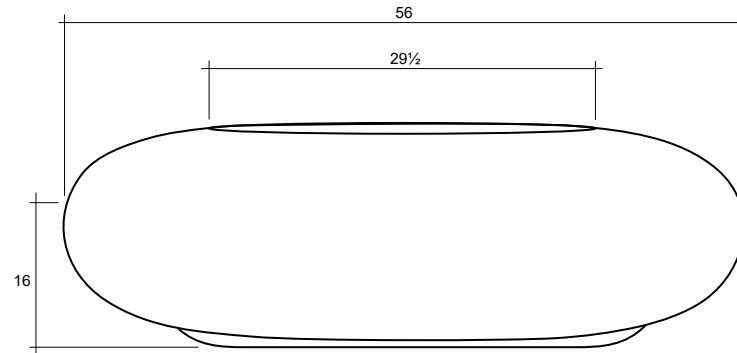

Rotondo



SPECIFICATIONS

Diameter	48"
Height	18"
Surface	11"
Burner Size	18" / 65,000 BTUs
Weight	430 lbs.
Fuel Source	LP or NG
Ignition	Key valve
Material	Glass fiber reinforced concrete
Media	Lava rock

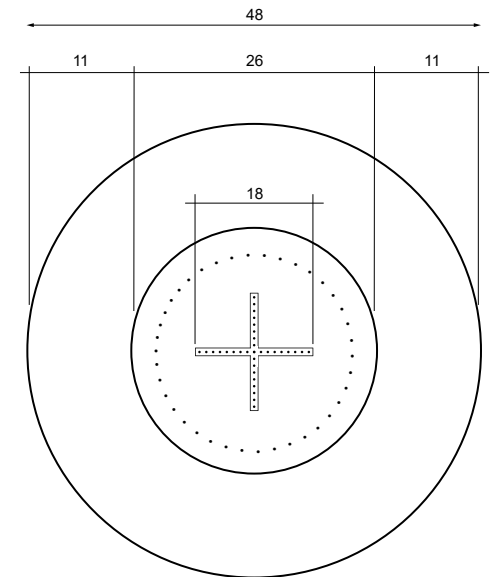
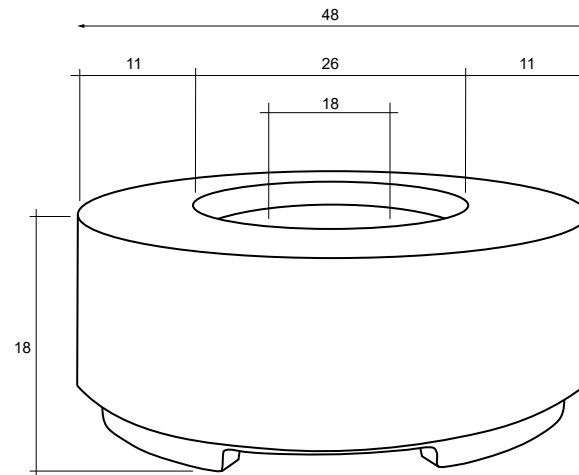

Lombard



SPECIFICATIONS

Width	40"
Height	18"
Surface	6 3/4"
Burner Size	18"/65,000 BTUs
Weight	280 lbs.
Fuel Source	LP or NG
Ignition	Key valve
Material	Glass fiber reinforced concrete
Media	Lava rock

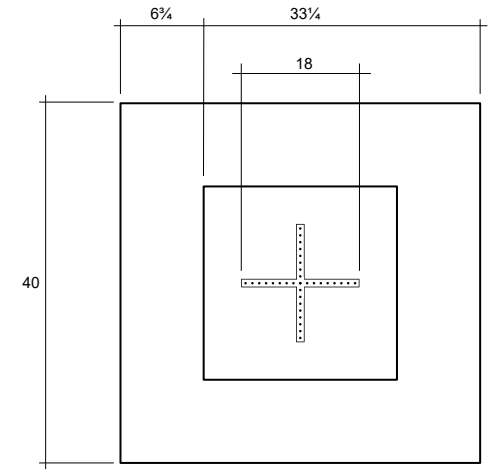
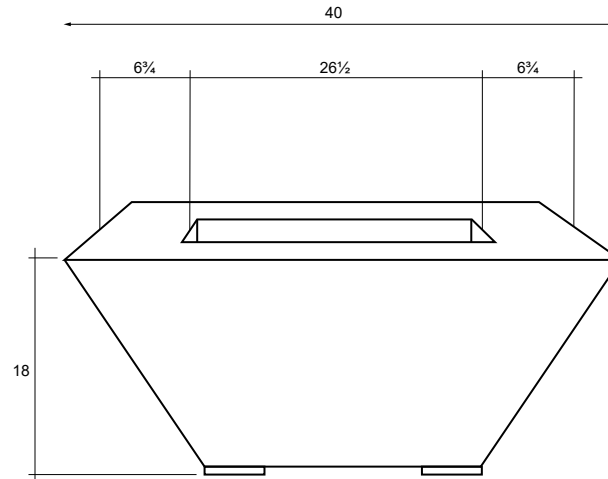

Embarcadero



SPECIFICATIONS

Diameter	48"
Height	15"
Surface	7"
Burner Size	18"/65,000 BTUs
Weight	225 lbs.
Fuel Source	LP or NG
Ignition	Key valve
Material	Glass fiber reinforced concrete
Media	Lava rock

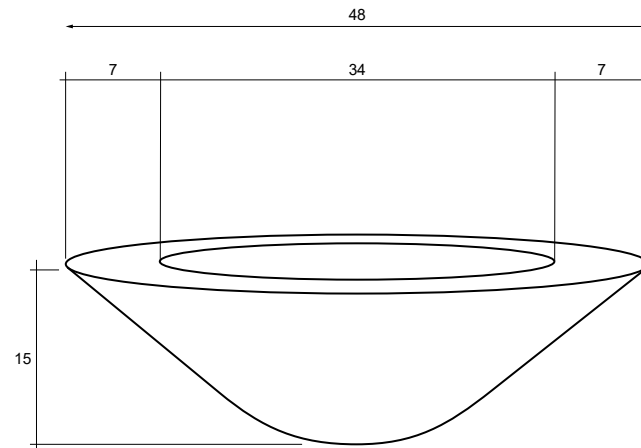

Mounting Plate Included

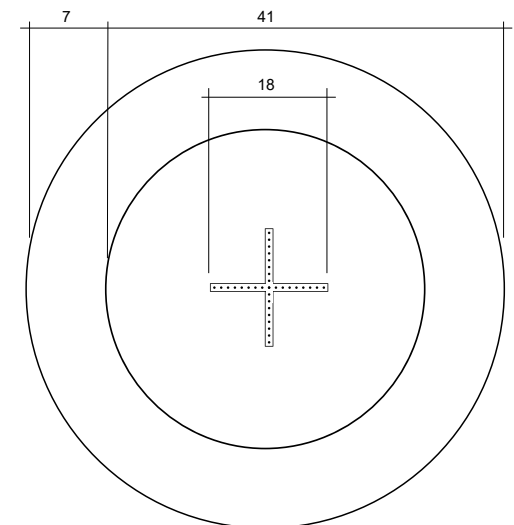



Embarcadero



Mod

Propane Enclosures



TAV SPECIFICATIONS

Width	20"
Height	21½"
Weight	100 lbs.
Material	Glass fiber reinforced concrete



MOD SPECIFICATIONS

Diameter	20"
Height	21½"
Weight	100 lbs.
Material	Glass fiber reinforced concrete



SAUSALITO SPECIFICATIONS

Width	16"
Height	21"
Weight	100 lbs.
Material	Glass fiber reinforced concrete



ORINDA SPECIFICATIONS

Diameter	15"
Height	20"
Weight	100 lbs.
Material	Glass fiber reinforced concrete

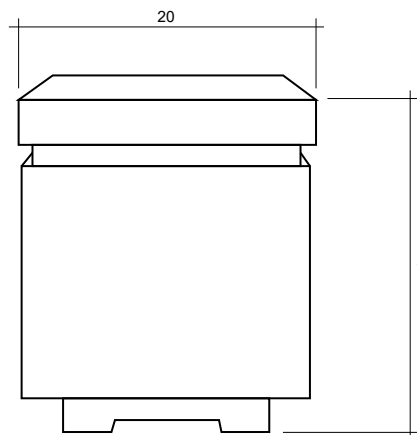

21½

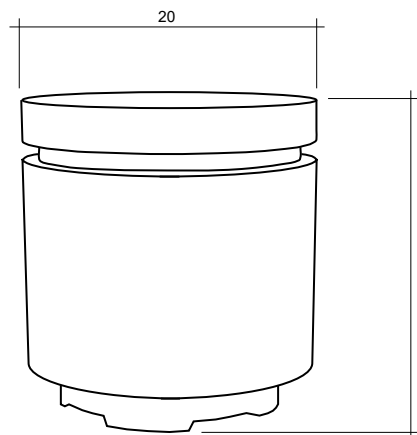

21½

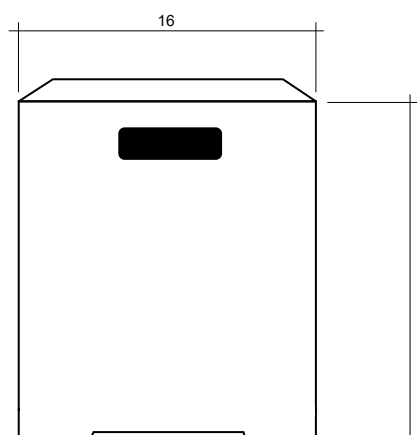

21

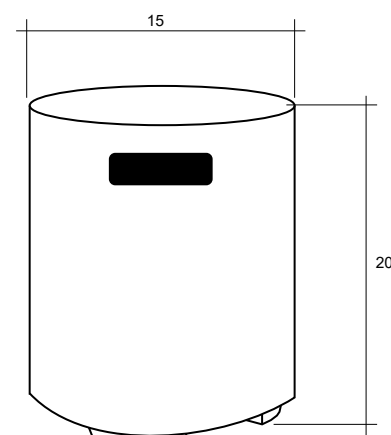

20

Lombard (Pedestal)

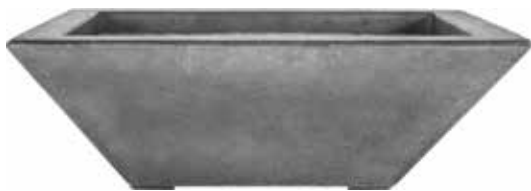

SPECIFICATIONS

Width	29"
Length	29"
Height	10"
Surface	3"
Burner Size	15"/65,000 BTUs
Weight	90 lbs.
Fuel Source	LP or NG
Ignition	Key valve
Material	Glass fiber reinforced concrete
Media	Lava rock

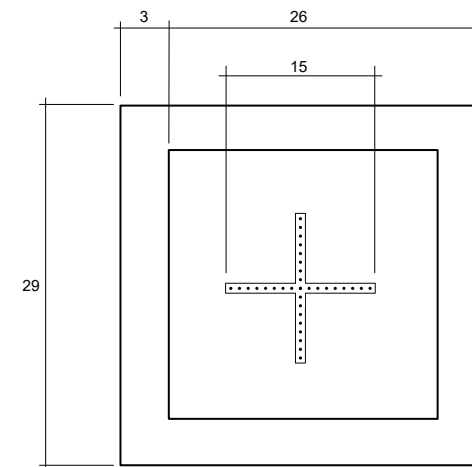
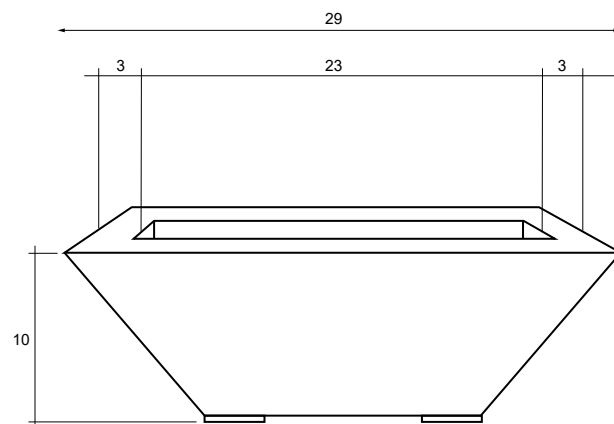

Embarcadero (Pedestal)



SPECIFICATIONS

Diameter	31"
Height	10"
Surface	2½"
Burner Size	15"/65,000 BTUs
Weight	90 lbs.
Fuel Source	LP or NG
Ignition	Key valve
Material	Glass fiber reinforced concrete
Media	Lava rock

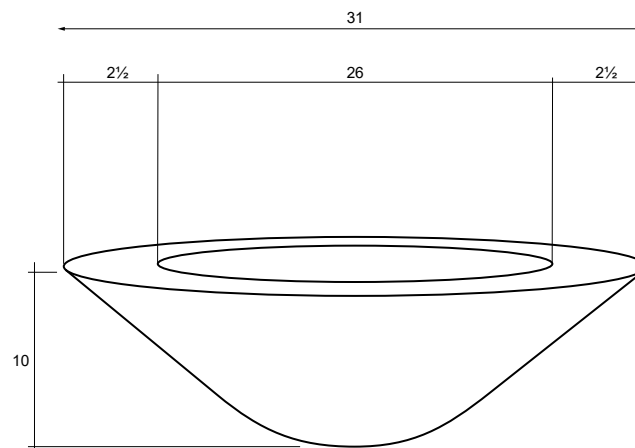

Mounting Plate Included

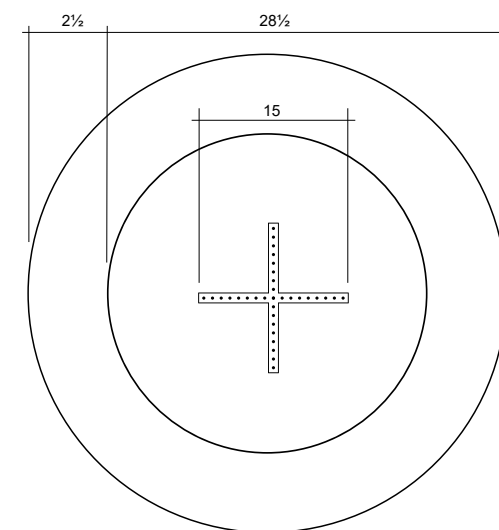

Moderno 70

SPECIFICATIONS

Diameter	70"
Height	18"
Surface	6" (also available in 14")
Burner Size	22"/125,000 BTUs
Weight	650 lbs.
Fuel Source	Natural gas or Liquid propane (larger tanks only)
Ignition	PH-Ignite (Electronic)
Material	Glass fiber reinforced concrete
Media	Tumbled lava rock

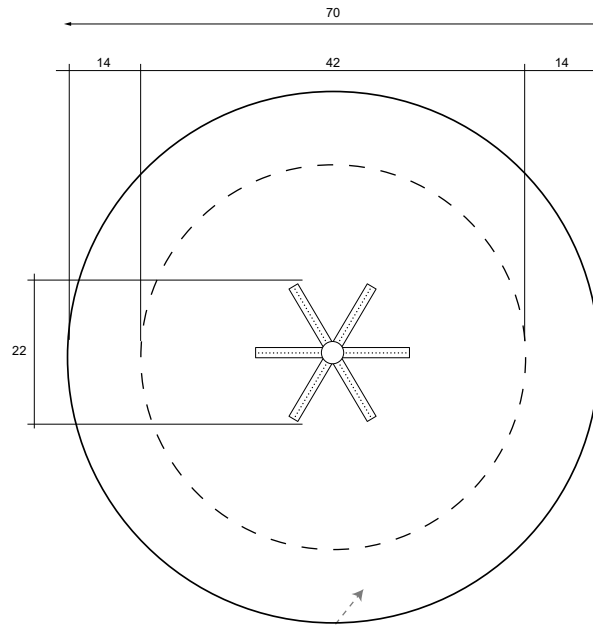

Available with 14" Surface

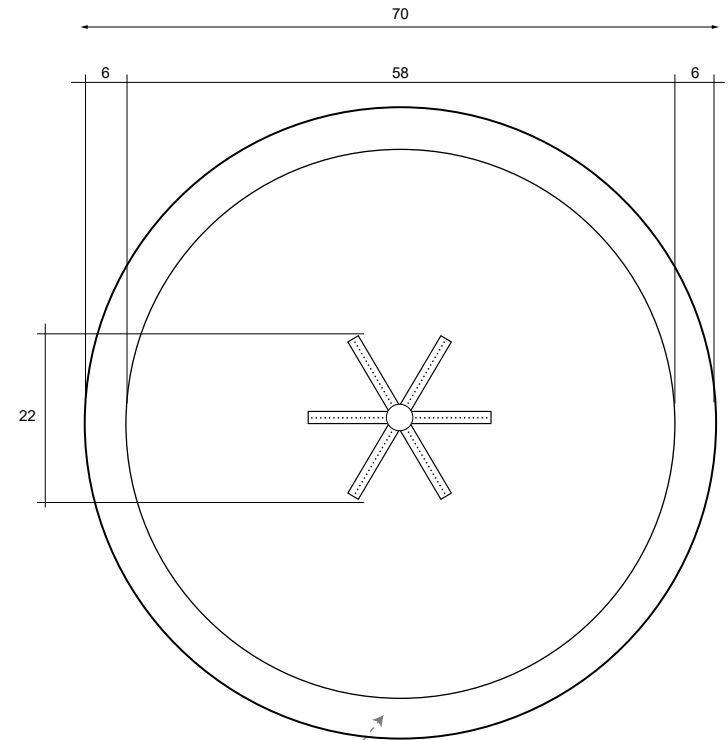

6" Standard Surface

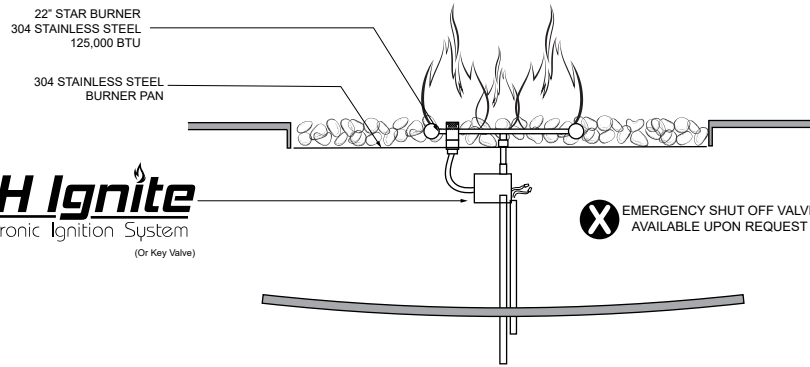

X EMERGENCY SHUT OFF VALVE
AVAILABLE UPON REQUEST

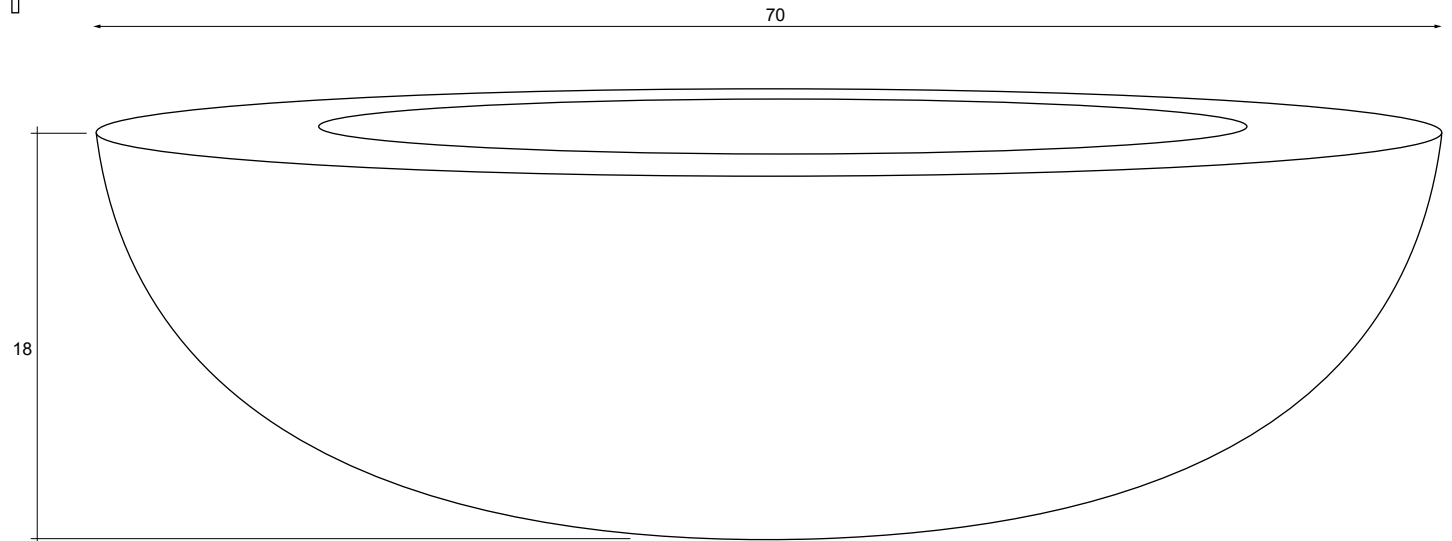



Moderno 70

Embarcadero 60

SPECIFICATIONS

Diameter	60"
Height	16"
Surface	17½"
Burner Size	18"/125,000 BTUs
Weight	550 lbs.
Fuel Source	Natural gas or Liquid propane (larger tanks only)
Ignition	PH-Ignite (Electronic)
Material	Glass fiber reinforced concrete
Media	Tumbled lava rock

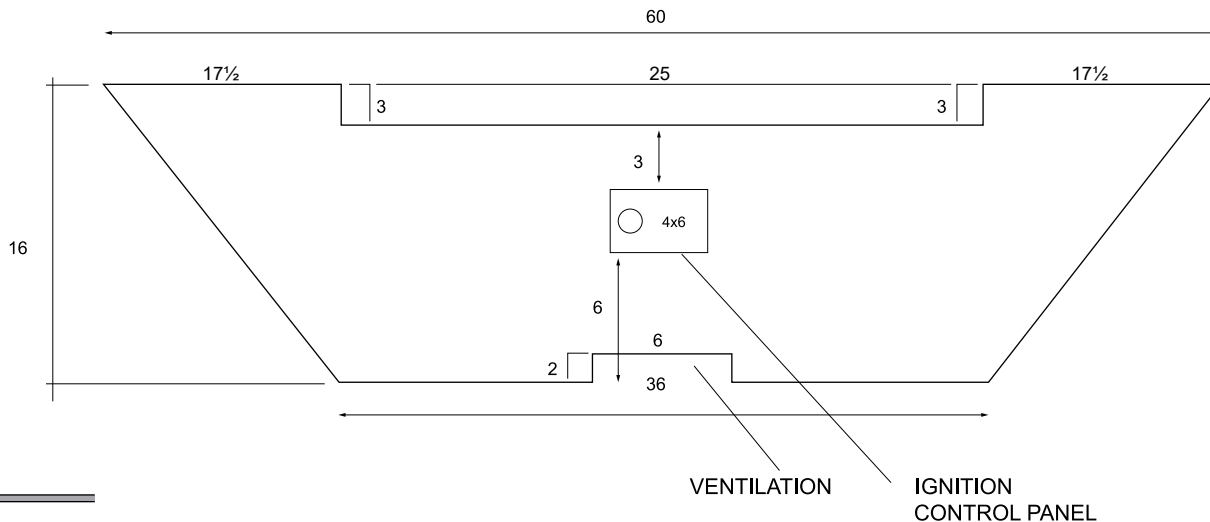

18" STAR BURNER
304 STAINLESS STEEL
125,000 BTU

304 STAINLESS STEEL
BURNER PAN

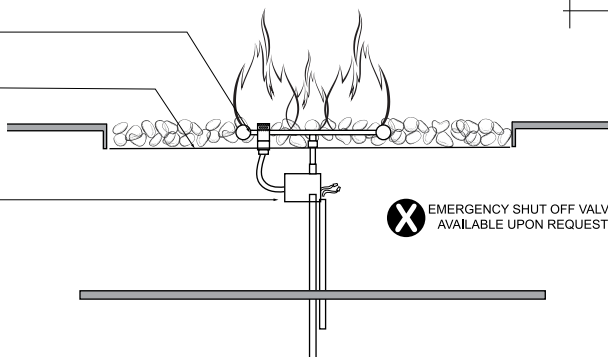

PH Ignite
Electronic Ignition System
(Or Key Valve)

X EMERGENCY SHUT OFF VALVE
AVAILABLE UPON REQUEST

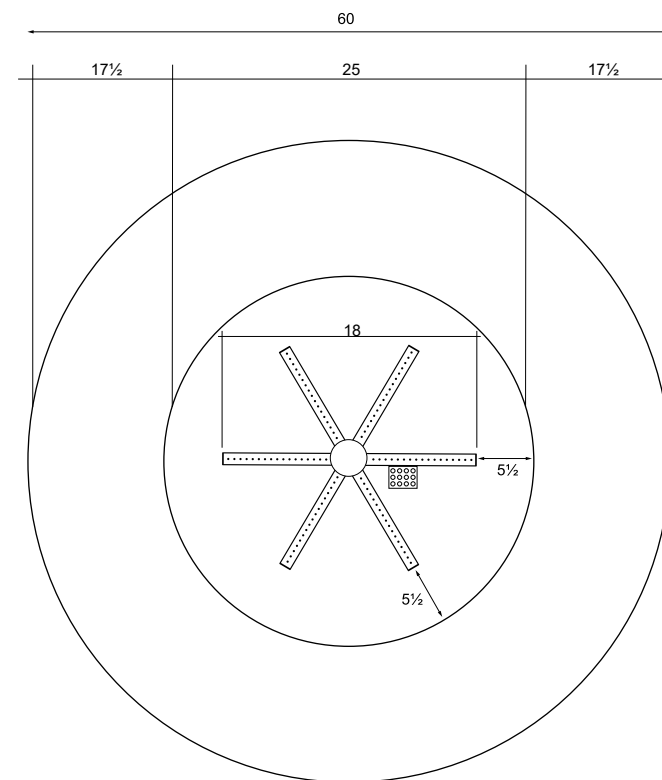

SPECIFICATIONS

Width	72"
Length	72"
Height	16"
Surface	12"
Burner Size	22"/125,000 BTUs
Weight	910 lbs.
Fuel Source	Natural gas or Liquid propane (large tanks only)
Ignition	PH-Ignite (Electronic)
Material	Glass fiber reinforced concrete
Media	Tumbled lava rock

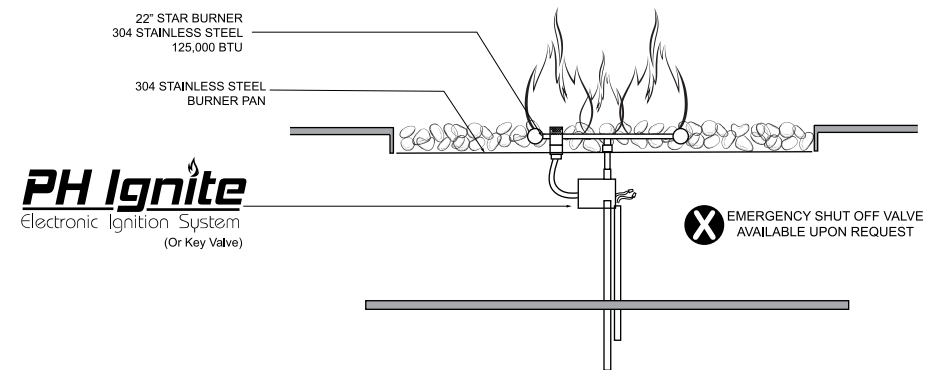
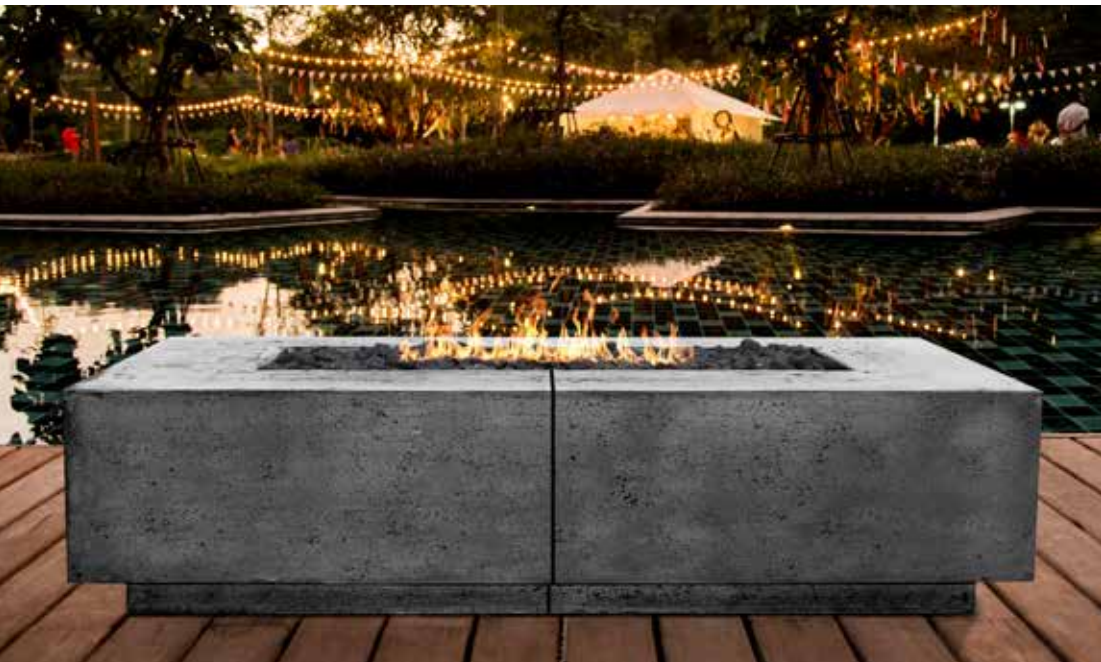
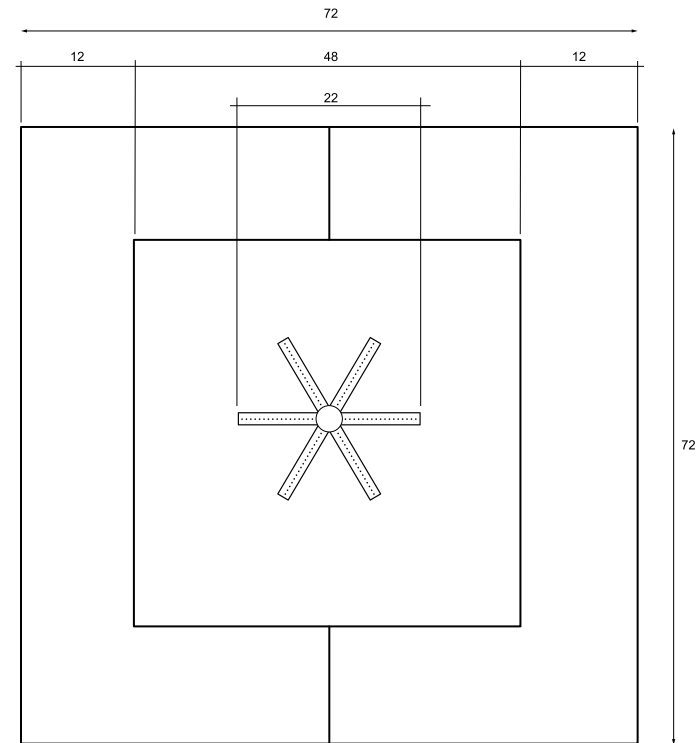
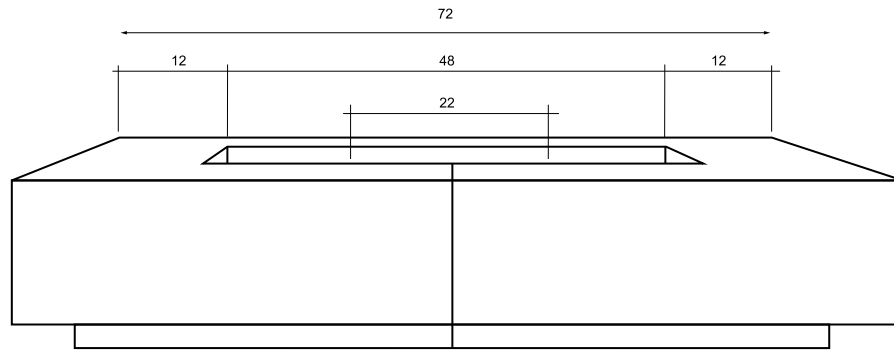

Largo 72

Largo 96 also available

SPECIFICATIONS

Diameter	80"
Height	18"
Surface	12"
Burner Size	22"/125,000 BTUs
Weight	700 lbs.
Fuel Source	Natural gas or Liquid propane (larger tanks only)
Ignition	PH-Ignite (Electronic)
Material	Glass fiber reinforced concrete
Media	Tumbled lava rock

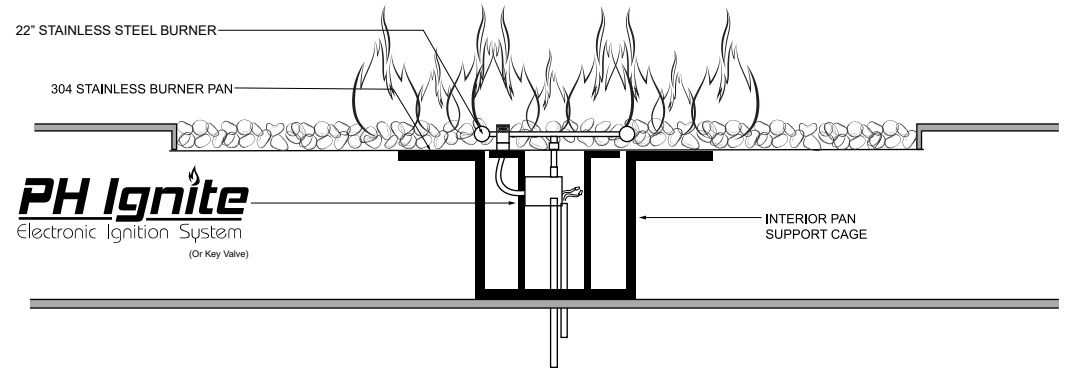
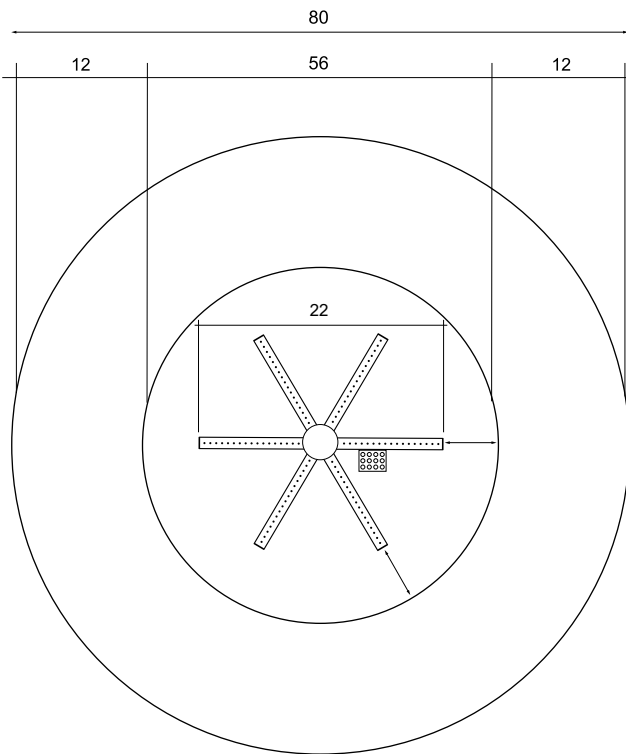
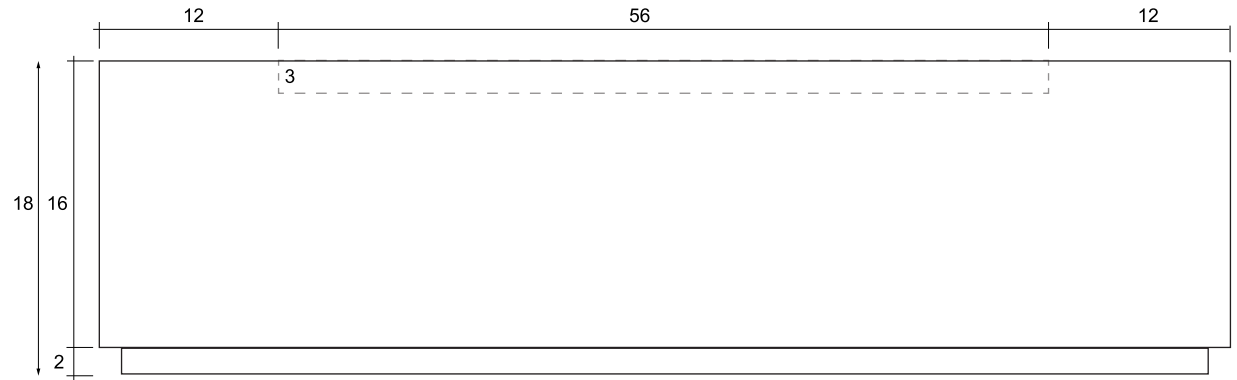

Rotondo 80



Fuego 89

Fuego Series

Fuego 89

Ignition Source:
PH-Ignite Electronic Ignition System



Fuego 89 Specifications

Diameter	89"
Height	16½"
Surface	24"
Burner Size	22"/125,000 BTUs
Weight	1050 lbs.
Fuel Source	Natural gas or Liquid propane (large tanks only)
Ignition	PH-Ignite (Electronic)
Material	Glass fiber reinforced concrete/Powder coated steel
Media	Tumbled lava rock

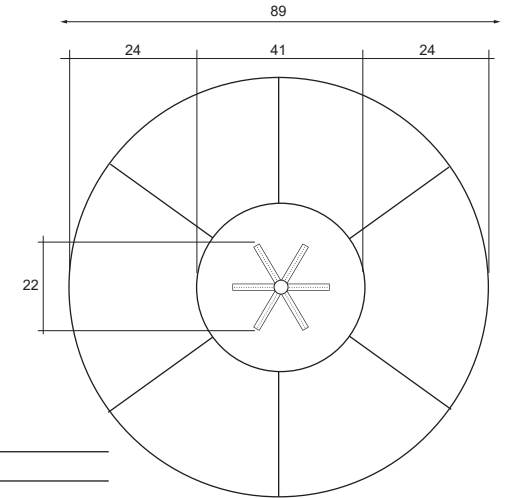

Fuego 54

Ignition Source:
PH-Ignite Electronic Ignition System

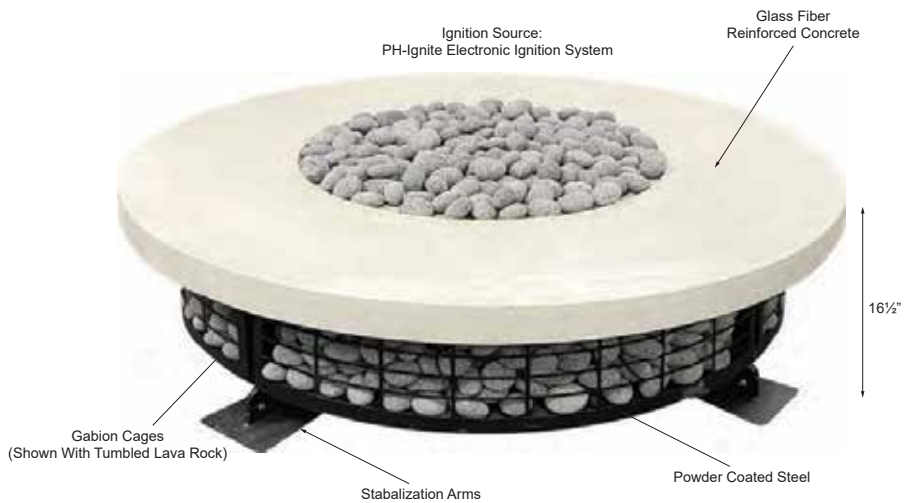

Fuego 54 Specifications

Diameter	54"
Height	16½"
Surface	12½"
Burner Size	22"/125,000 BTUs
Weight	550 lbs.
Fuel Source	Natural gas or Liquid propane (large tanks only)
Ignition	PH-Ignite (Electronic)
Materials	Glass fiber reinforced concrete/Powder coated steel
Media	Tumbled lava rock

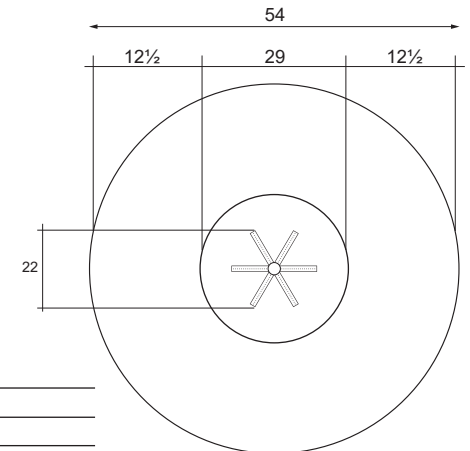

Edel Collection



Moderno 4



MODERNO 1

SPECIFICATIONS

Diameter	39"
Surface	3"
Height	18"
Burner Size	15"/65,000 BTUs
Weight	71 lbs.
Fuel Source	LP or NG
Ignition	Key valve
Material	Bush hammered copper
Media	Tumbled lava rock

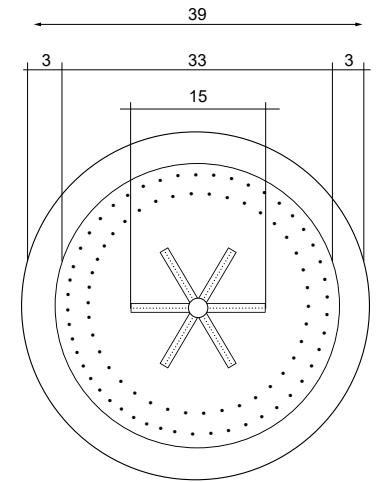
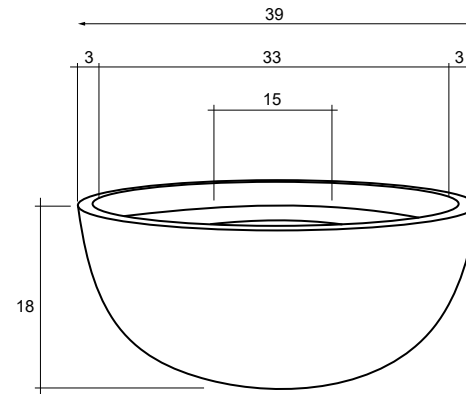

MODERNO 3

SPECIFICATIONS

Diameter	30"
Surface	3"
Height	18"
Burner Size	15"/65,000 BTUs
Weight	51 lbs.
Fuel Source	LP or NG
Ignition	Key valve
Material	Bush hammered copper
Media	Tumbled lava rock

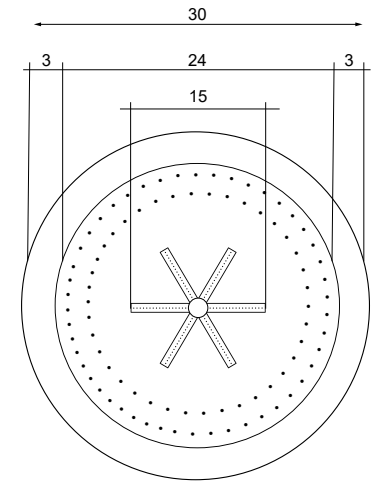
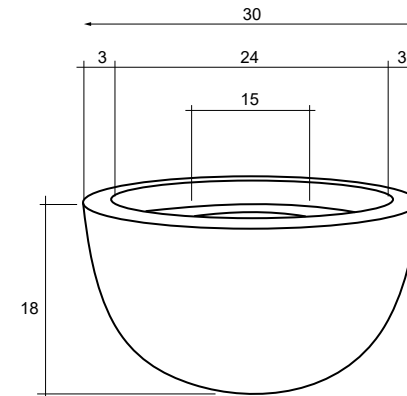

MODERNO 4

SPECIFICATIONS

Diameter	48"
Surface	4"
Height	17"
Burner Size	18"/65,000 BTUs
Weight	102 lbs.
Fuel Source	LP or NG
Ignition	Key valve
Materials	Bush hammered copper
Media	Tumbled lava rock

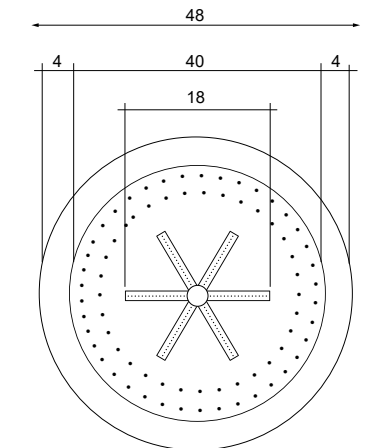
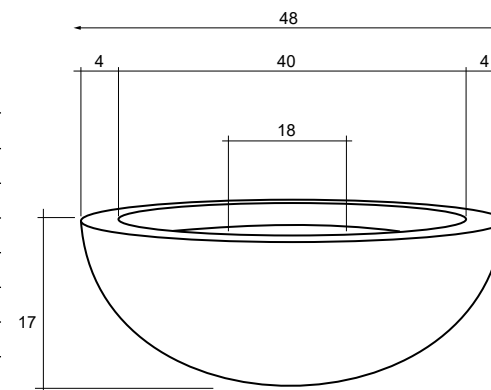

NEW PRODUCTS



Tuscany Cilindro

Tuscany Collection

Available Summer 2021

Models:

- Cilindro
- Rotondo
- Tavola 4
- Tavola 42
- Moderno 4



Coastal (New Color)



Ebony



Pewter



Ultra White

Ultra White



SPECIFICATIONS

Diameter	36"
Height	18"
Surface	6½"
Burner Size	15"/65,000 BTUs
Weight	350 lbs.
Fuel Source	LP or NG
Ignition	Key valve
Material	Glass fiber reinforced concrete
Media	Lava rock

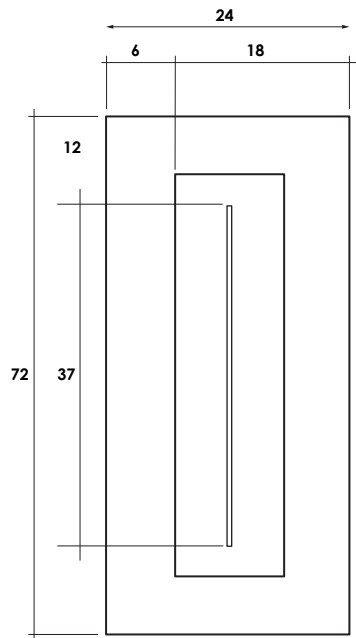

SPECIFICATIONS

Width	24"
Length	72"
Height	16"
Surface	12"/6"
Burner Size	37"/65,000 BTUs
Weight	400 lbs.
Fuel Source	LP or NG
Ignition	Key valve
Material	Glass fiber reinforced concrete
Media	Lava rock



Tavola 72 Narrow Series

Piazza

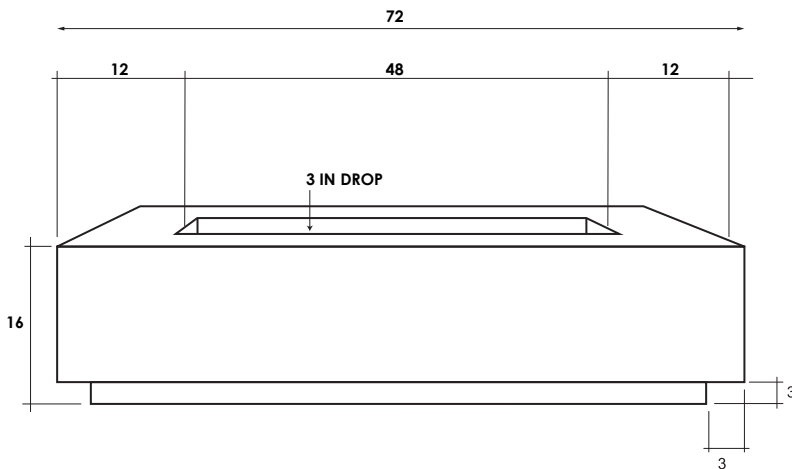
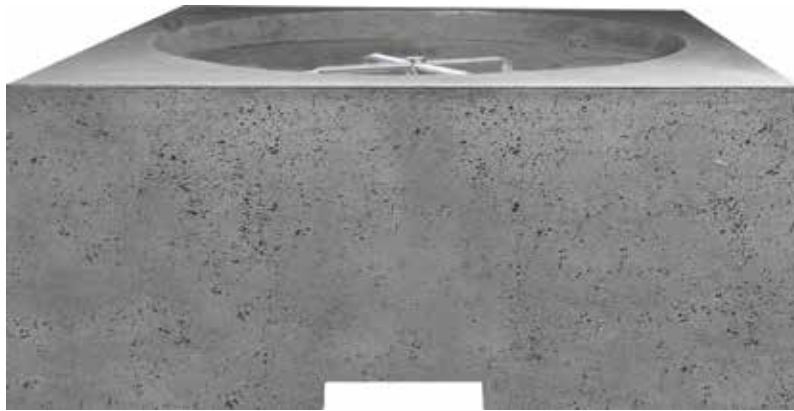

SPECIFICATIONS

Width	39"
Length	39"
Height	15¾"
Surface	3½"
Burner Size	15"/65,000 BTUs
Weight	360 lbs.
Fuel Source	LP or NG
Ignition	Key valve
Material	Glass fiber reinforced concrete
Media	Lava rock

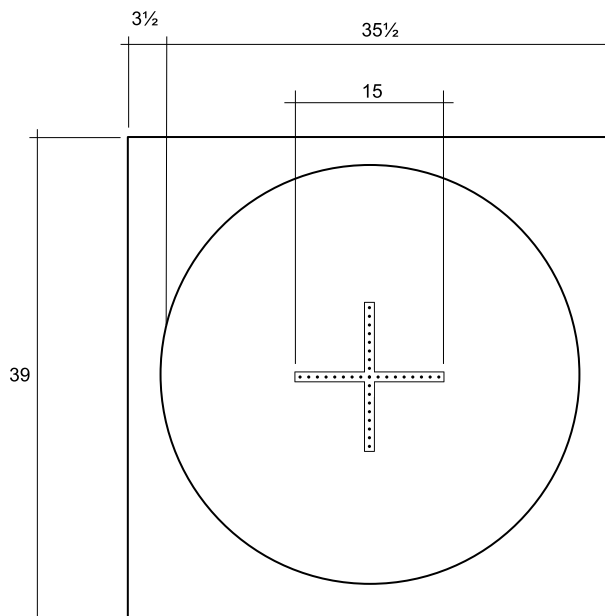
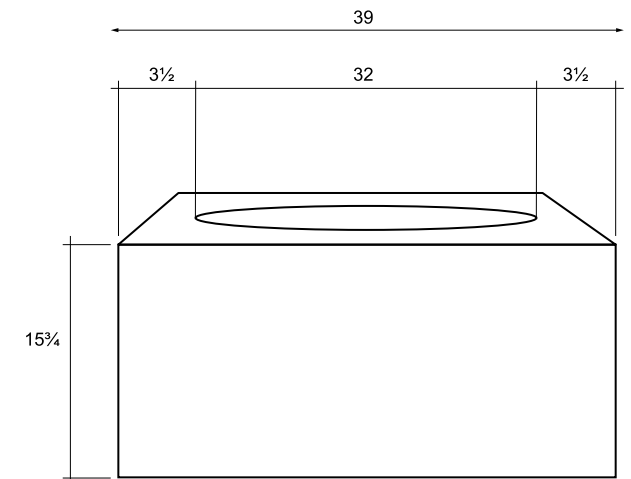

Cilindro



SPECIFICATIONS

Diameter	36"
Height	18"
Surface	6½"
Burner Size	15"/65,000 BTUs
Weight	350 lbs.
Fuel Source	LP or NG
Ignition	Key valve
Material	Glass fiber reinforced concrete
Media	Lava rock

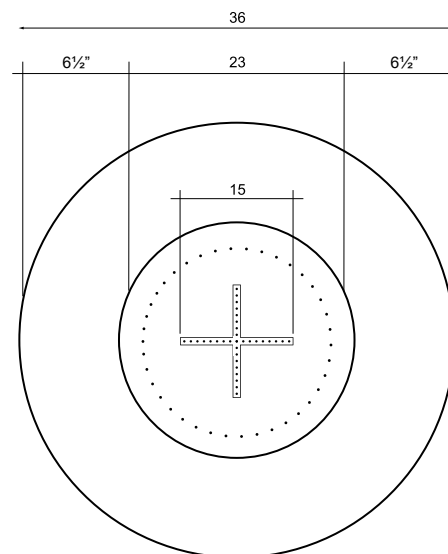
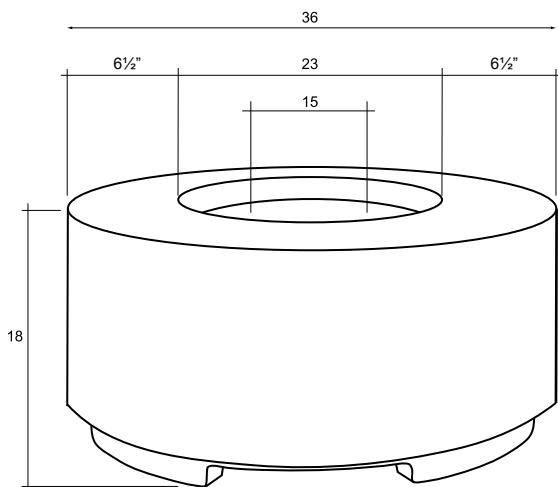

Triton

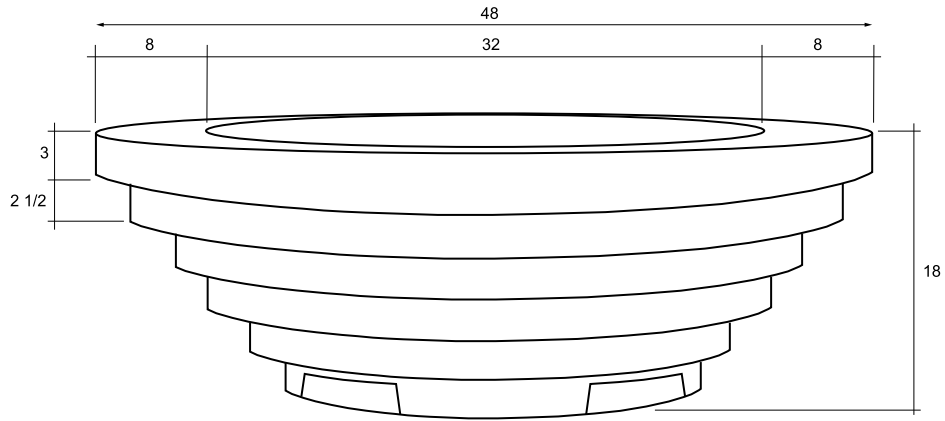

SPECIFICATIONS

Diameter	48"
Height	18"
Surface	8"
Burner Size	15"/65,000 BTUs
Weight	400 lbs.
Fuel Source	LP or NG
Ignition	Key valve
Material	Glass fiber reinforced concrete
Media	Lava rock

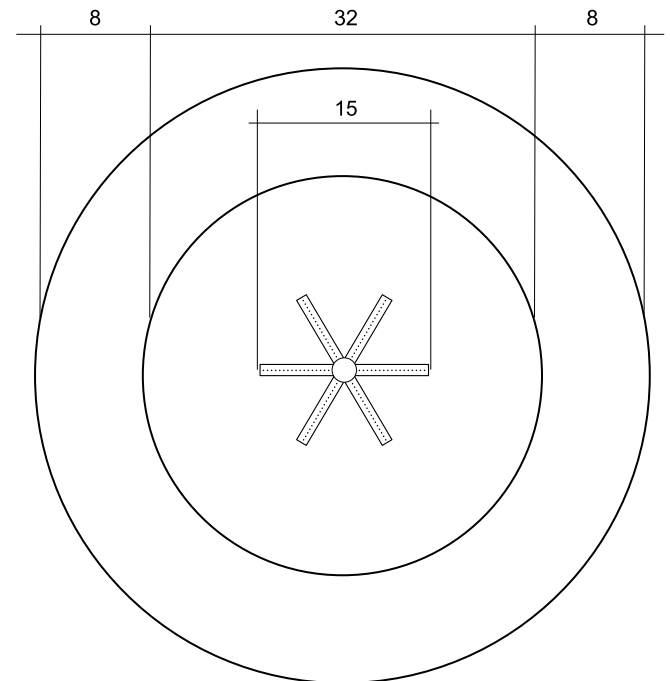

Triton

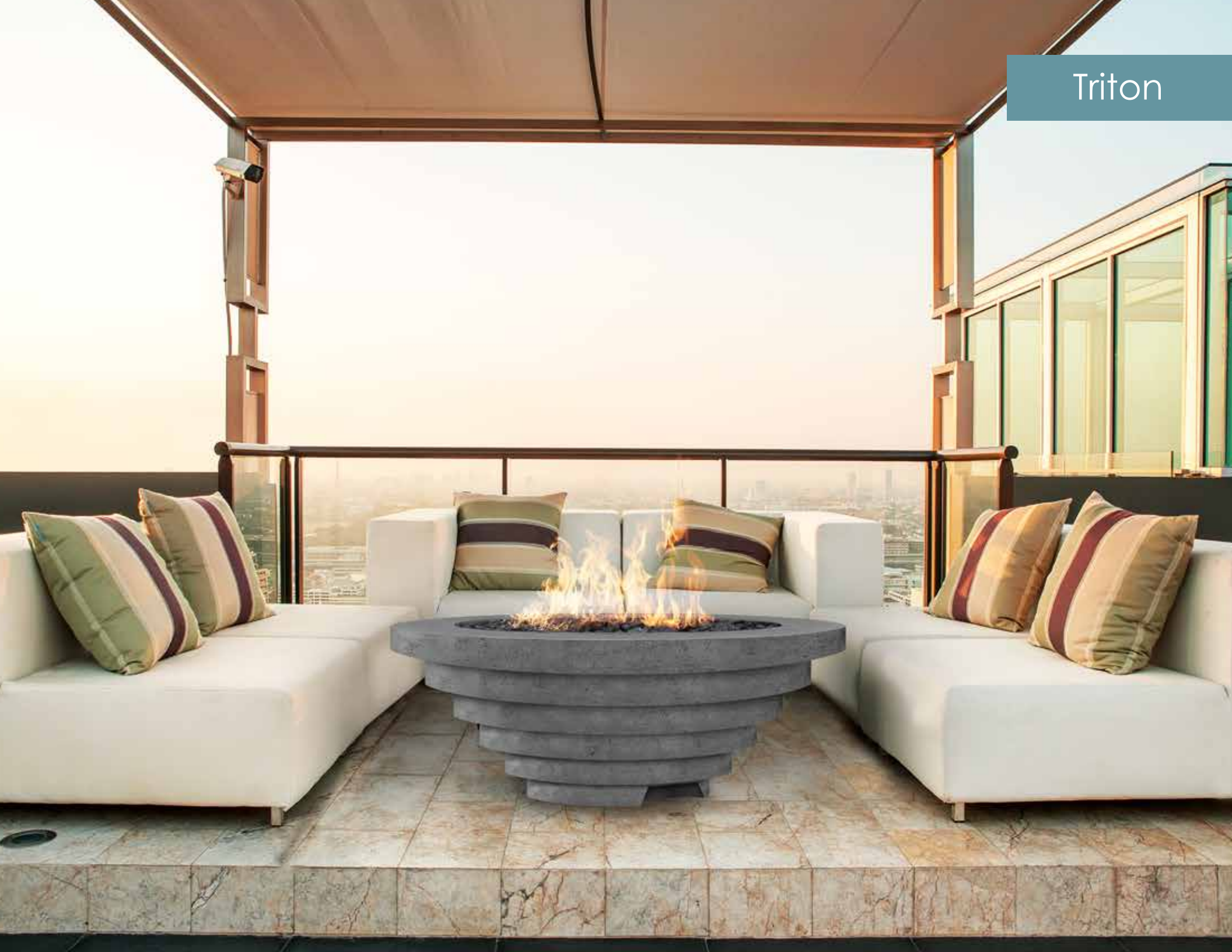

Ovale

SPECIFICATIONS

Width	45"
Length	79"
Height	18"
Surface	10"
Burner Size	30"/65,000 BTUs
Weight	320 lbs.
Fuel Source	LP or NG
Ignition	PH-Ignite (Electronic)/Key valve
Material	Glass fiber reinforced concrete
Media	Tumbled lava rock

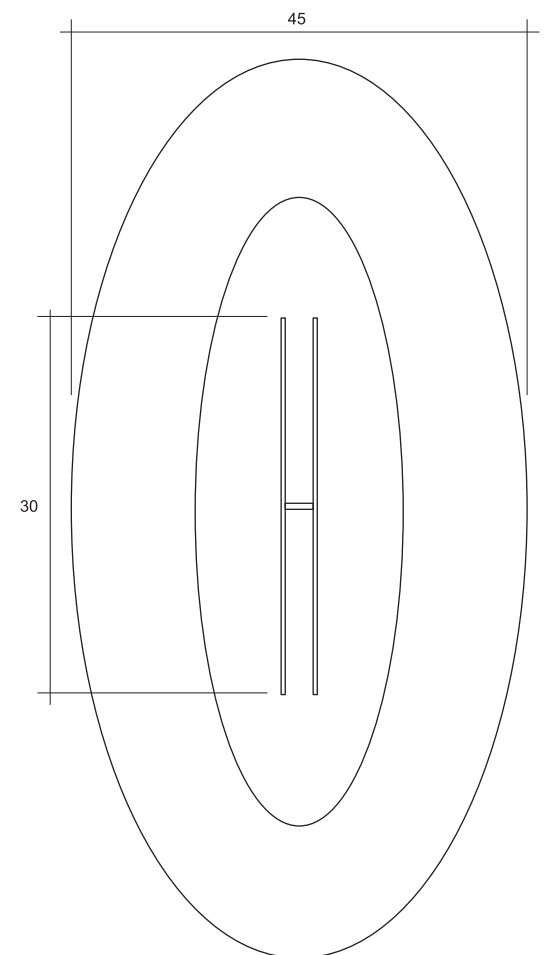
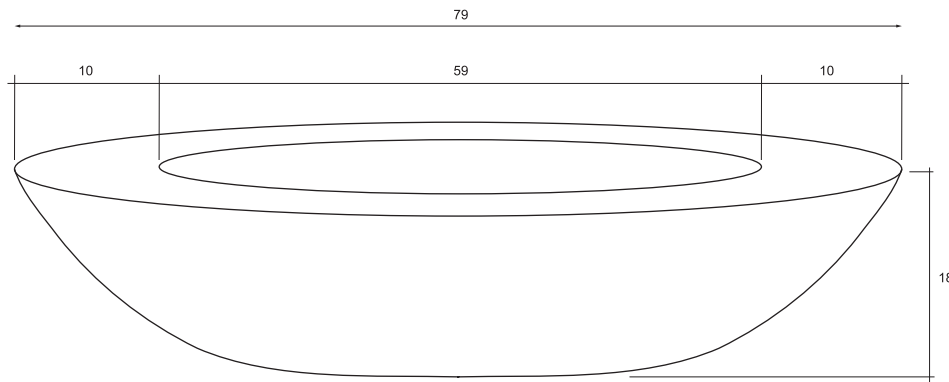

Elements Collection

Our Elements Collection offers beautiful pieces that combine 3 main elements: wood, concrete, and metal. A stout powder-coated metal frame is the foundation for all of the collection's fire features. Sturdy glass fiber reinforced concrete makes for a durable yet smooth-looking top centerpiece. While South American hardwood adds a decorative and refined appearance. The contrasting organic and industrial elements combine to create a look that is both intriguing and timeless.





Fairmont



Hampton



Manchester

Fairmont



SPECIFICATIONS

Width	35 $\frac{3}{4}$ "
Length	72 $\frac{3}{4}$ "
Height	17"
Surface	9 $\frac{1}{2}$ "
Burner Size	37"/65,000 BTUs
Weight	450 lbs.
Fuel Source	LP or NG
Ignition	Key valve
Materials	Glass fiber reinforced concrete Brazilian wood (outer) Metal frame (inner)
Media	Tumbled lava rock

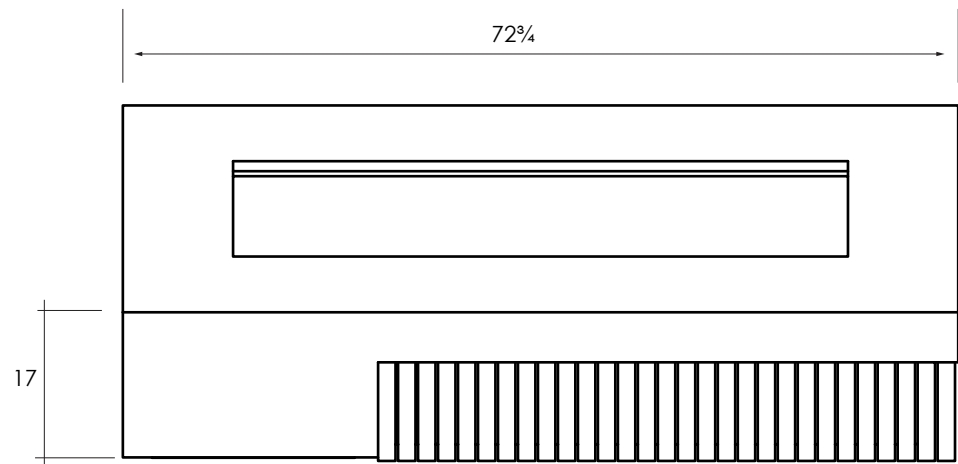
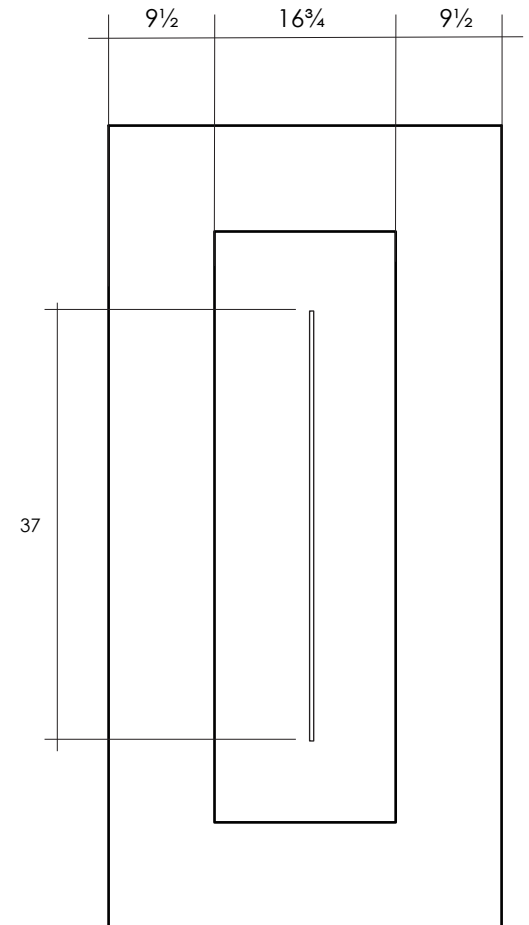

Hampton



SPECIFICATIONS

Diameter	48"
Height	18"
Surface	11"
Burner Size	18"/65,000 BTUs
Weight	430 lbs.
Fuel Source	LP or NG
Ignition	Key valve
Materials	Glass fiber reinforced concrete Brazilian wood (outer) Metal frame (inner)
Media	Tumbled lava rock

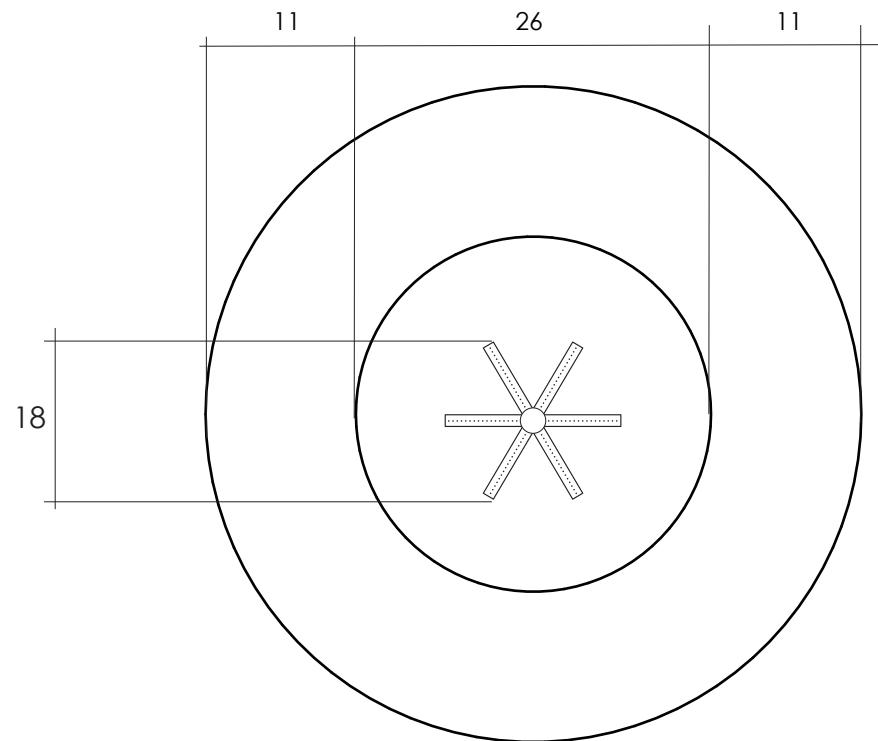
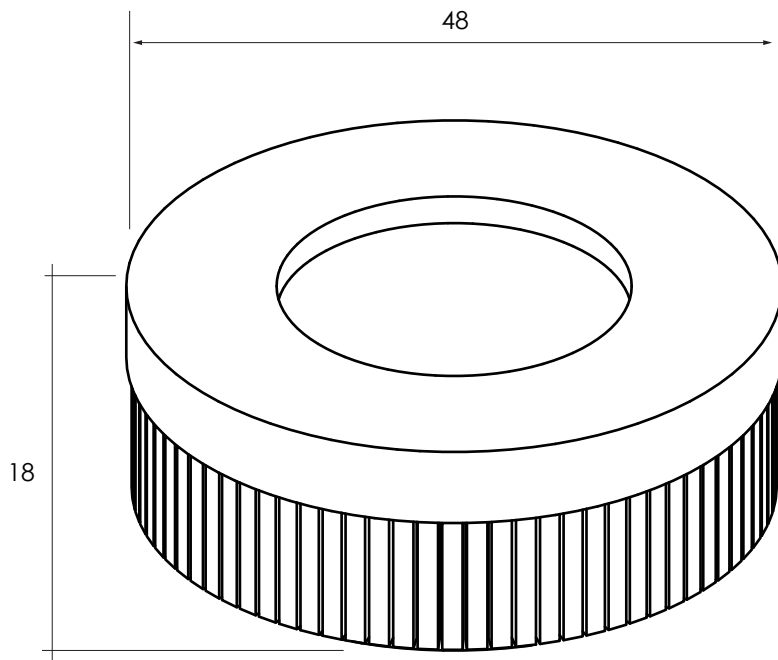

Manchester

SPECIFICATIONS

Width	42"
Length	42"
Height	16"
Surface	12"
Burner Size	12"/65,000 BTUs

Weight	450 lbs.
Fuel Source	LP or NG
Ignition	Key valve
Materials	Glass fiber reinforced concrete Brazilian wood (outer) Metal frame (inner)
Media	Tumbled lava rock

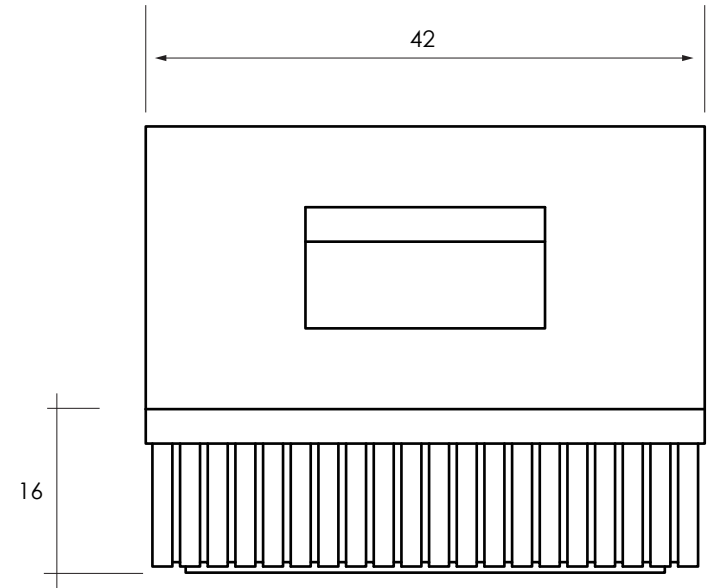
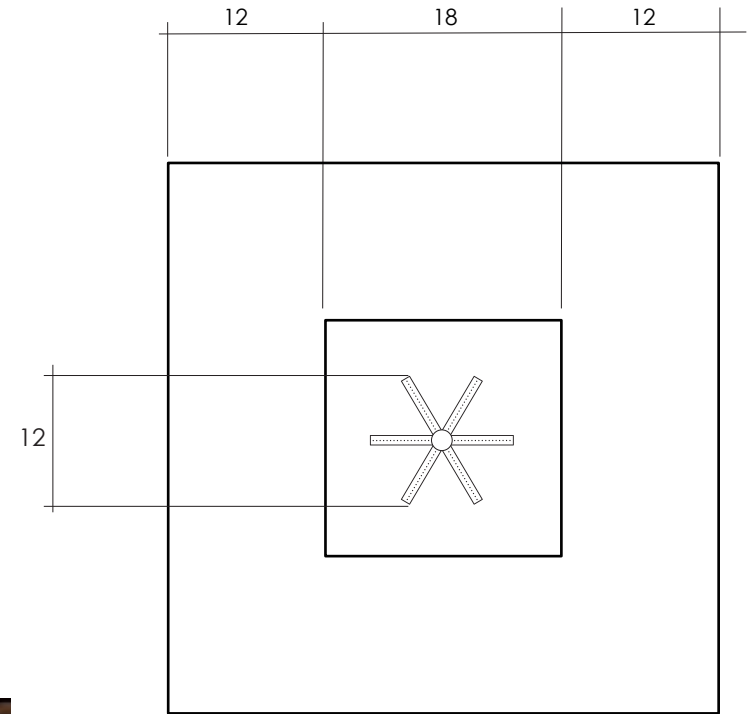

Falò (Wood Burning)

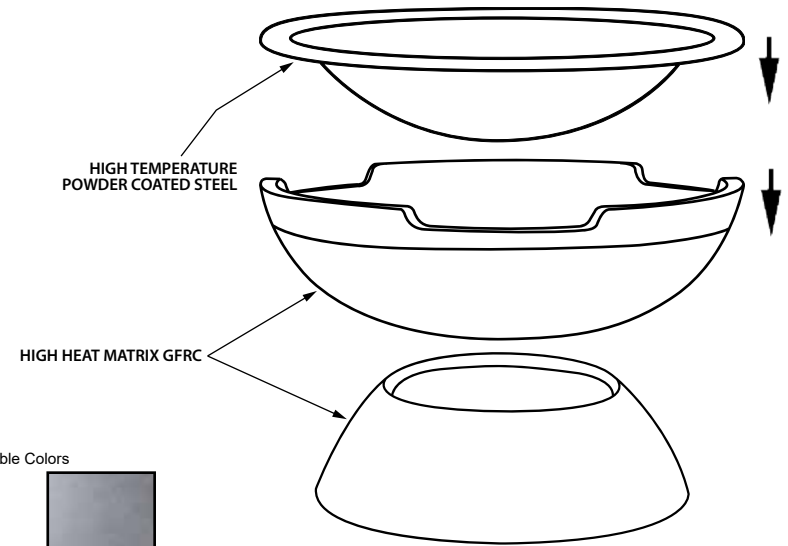
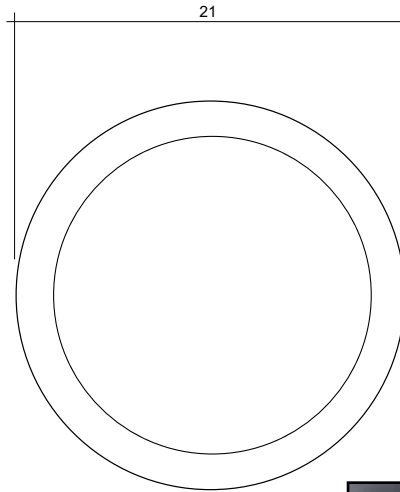

SPECIFICATIONS

Diameter	21"
Height	10½"
Weight	30 lbs.
Fuel Source	Wood
Material	Glass fiber reinforced concrete
Burner Pan	High temp powder coated steel



LIGHT WEIGHT



QUICK ASSEMBLY



RUST RESISTANT



FROST RESISTANT



EASY DISPOSAL



HEAT RESISTANT



create the perfect environment

- fire anytime, anywhere.

With Falò's lightweight and portable design, you can create the perfect lighting, warmth and ambiance for an evening with friends & family.

- modern design

Falò uses the perfect blend of design and modern materials to create the lightweight, sleek look of the fire bowl, while maintaining the integrity of the materials under extreme conditions.

- portability

Falò uses state of the art technology to create the perfect accessory for your outdoor setting. Lightweight yet strong, use Falò at your home, or take it with you for an outdoor adventure. Falò's quick assembly allows for easy travel and set up.



Falò

Fire Media

Prism Hardscapes offers multiple fire feature medias including:

- 3/4" Lava Rock
- Tumbled Lava Rock
- Fire Glass (7 colors)

Fire Glass



Aqua



Black



Mist



Clear



Smoke



Azura



Bronze

3/4" Lava Rock



Tumbled Lava Rock



PH ENGINEERING

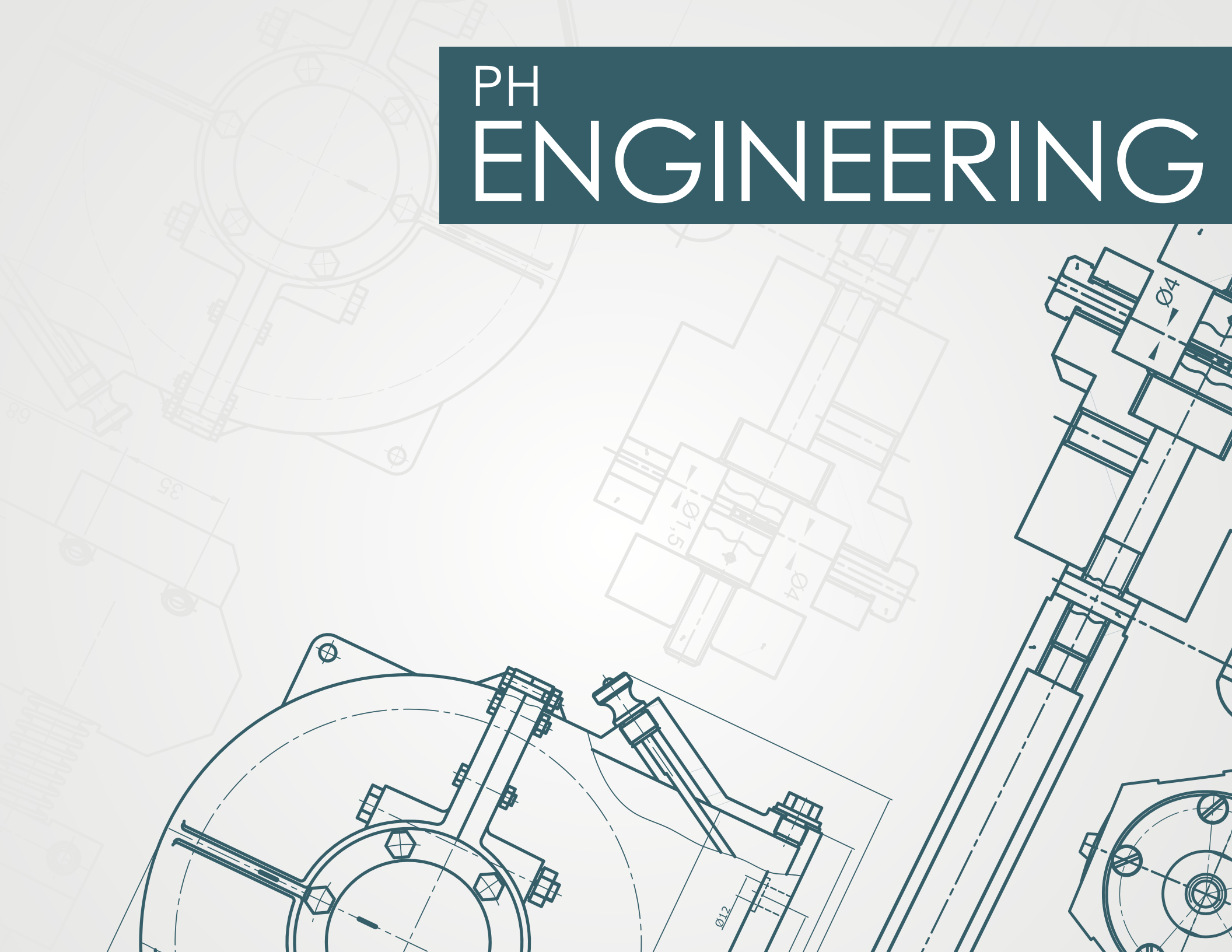



Hassle-Free Ignition, Zero Worries

Hot Surface Ignition

Robust and reliable ignition.

Waterproof Pilot Connector

Corrosion proof electrical connection.

Compact Design

Conveniently fits into your fire feature.

Electronic Ignition

Convenient fire feature lighting and instant flame monitoring.

Weatherproof/Anti-Corrosion Enclosure

Protects internal components from harsh weather and is built to last.

12 VAC Inlet Power

Compliant with National Electrical code 2014, article 68. May be installed within five feet of pool water.



This product complies with ANSI Z2197 standard.

*Burner not included. System connects to existing fire feature burner.

Ignition Options

- Key Valve
- Battery Ignition
- Electronic



Key Valve



Battery Ignition



Electronic

SPECIFICATIONS

Fuel Source	Propane Gas (LP) or Natural Gas (NG)
Ignition	Manual Key Turn
Ignition Source	Match Lit

SPECIFICATIONS

Fuel Source	Propane Gas (LP) or Natural Gas (NG)
Ignition	Press Button Start w/Safety Auto Cut-off
Ignition Source	Battery Spark

SPECIFICATIONS

Fuel Source	Propane Gas (LP) or Natural Gas (NG)
Ignition	Electric Switch
Ignition Source	Electric Spark



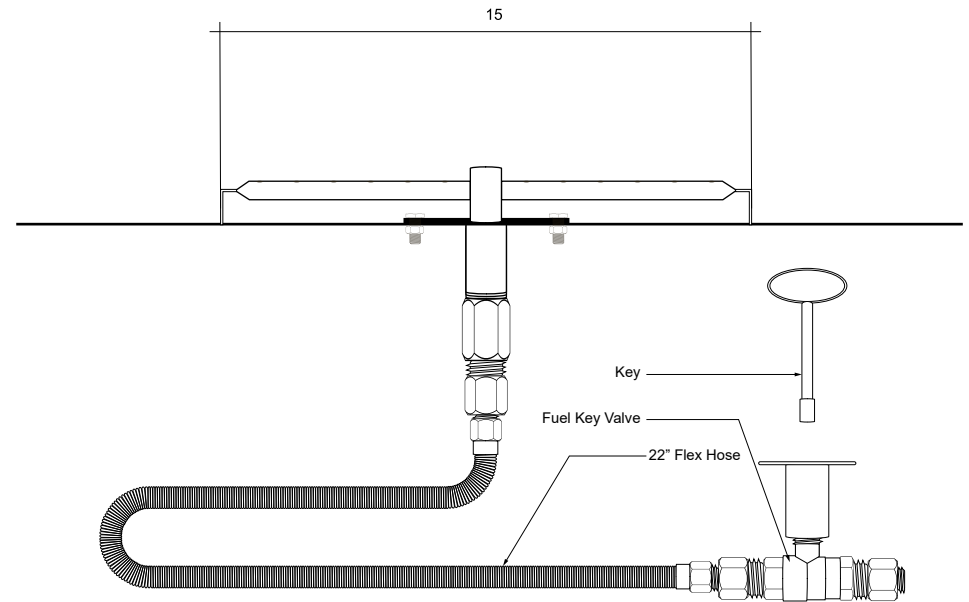
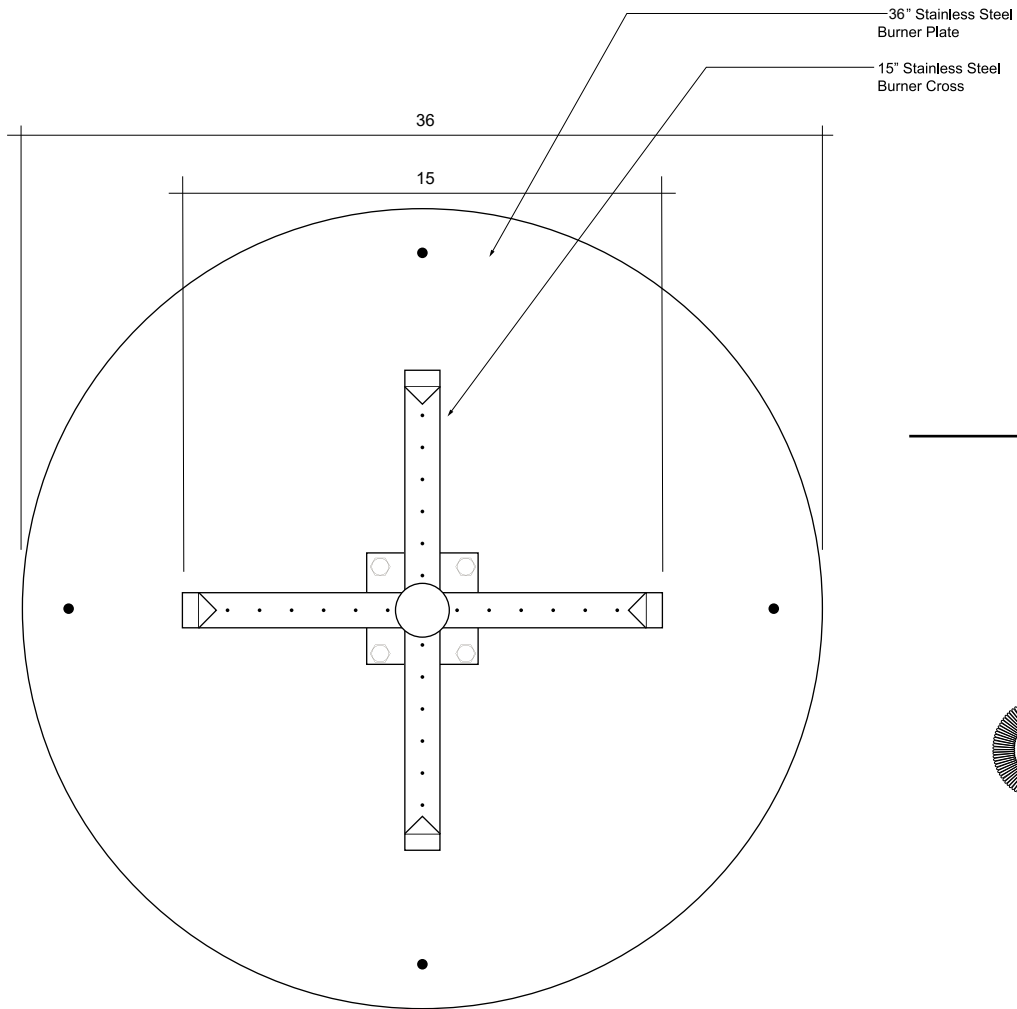

New Cross Burner Specifications

- Made in the USA
- 65,000 BTU's
- Key Valve Ignition
- 304 Stainless Steel
- Tested to meet CSA/ANSI standards
- 2-year Warranty





CLUB CHAIR

Divano

DIVANO

EDEL Hospitality Collection

GFRC Color Options

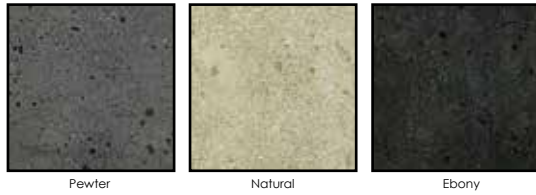

Cushion/Pillow Color Options (Sold Separately)

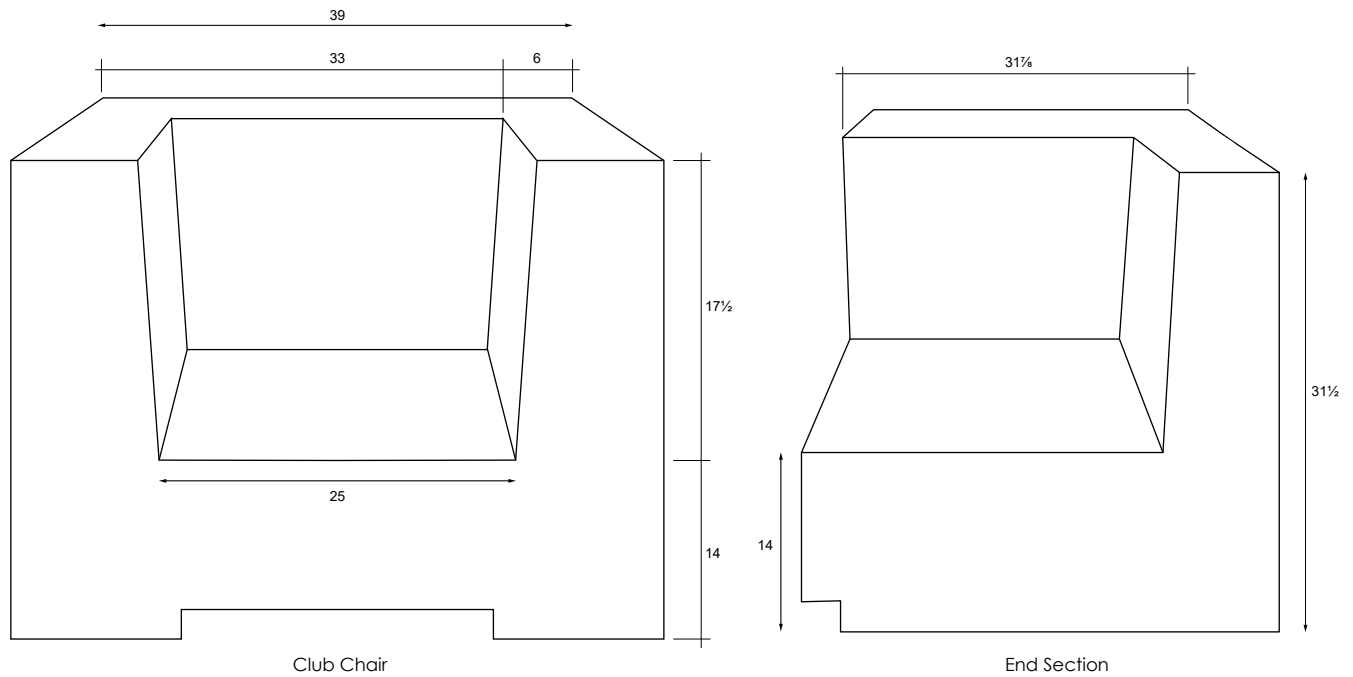
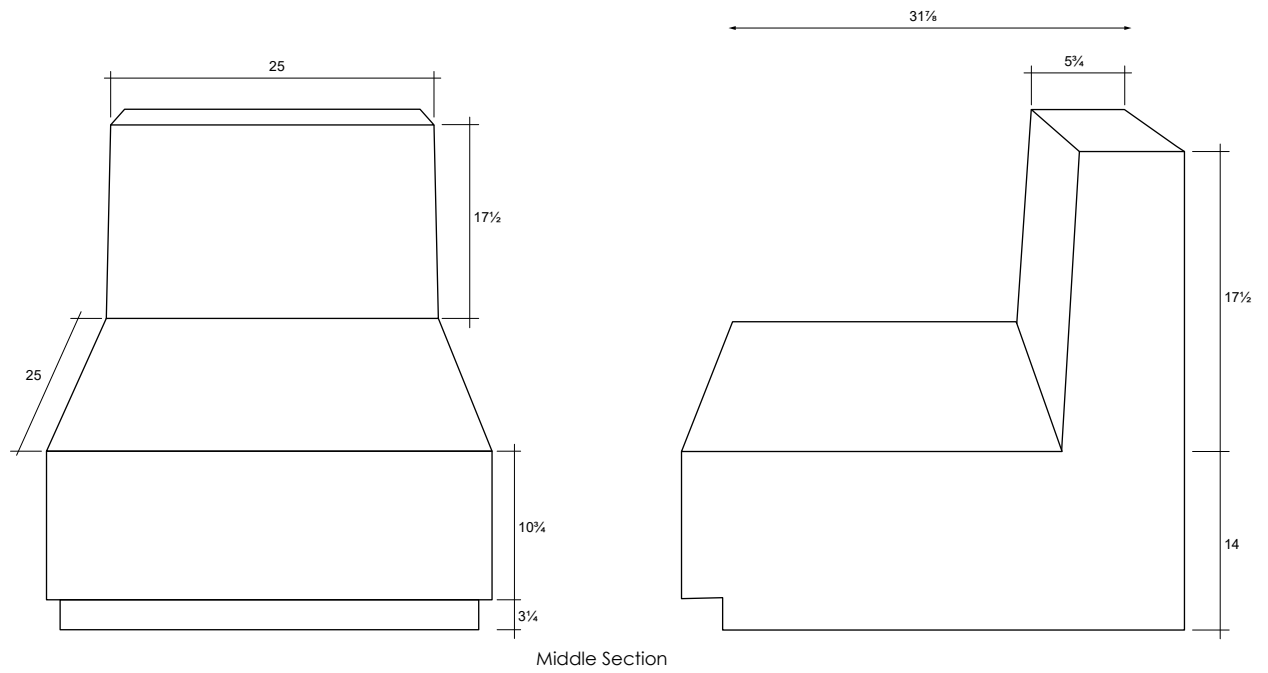
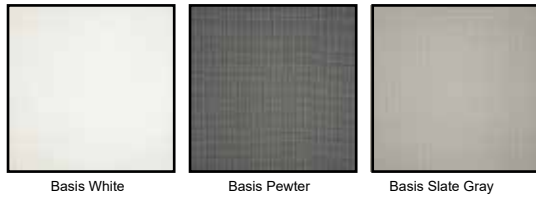



CRAFTSMANSHIP

From concept to finished product, outstanding craftsmanship is present in every aspect of our process. Each of our products has been hand-crafted using our own patina finishing process guaranteeing a one-of-a-kind subtle variation and creation.





Rotondo

Live Outdoors



Prism Hardscapes creates dependable and custom outdoor living products to help bring your ideas and visions to life.

Breaking ground on a new project is key, but planning before-hand is crucial. This means selecting products in different colors, shapes and sizes that will create the ideal outdoor living space to fit your lifestyle and vision. Let Prism Hardscapes help get you there.

